

Viviana Ruiz Gutiérrez • Humberto Antonio Berlanga García • Rafael Calderón Parra
Annamaria Savarino Drago • Miguel Ángel Aguilar Gómez • Vicente Rodríguez Contreras

PROALAS

Latin American Landbird Program



Illustrated Manual for Monitoring Landbirds



CONABIO

PROALAS

Latin American Landbird Program

Illustrated Manual for Monitoring Landbirds

Viviana Ruiz Gutiérrez ¹

Humberto Antonio Berlanga García ²

Rafael Calderón Parra ²

Annamaria Savarino Drago ²

Miguel Ángel Aguilar Gómez ²

Vicente Rodríguez Contreras ²

1. The Cornell Laboratory of Ornithology

2. National Commission for the Knowledge and
Use of Biodiversity (CONABIO) / North American Bird
Conservation Initiative (NABCI-Mexico).



CONABIO

COMISIÓN NACIONAL PARA
EL CONOCIMIENTO Y USO
DE LA BIODIVERSIDAD

The **Cornell** Lab  of Ornithology

First edition, July 2020

D.R. © 2020, National Commission for the Knowledge and Use of Biodiversity (CONABIO)
Periférico-Insurgentes Sur 4903, Parques del Pedregal Tlalpan Delegation, Mexico City, 14010

www.gob.mx/conabio / www.biodiversidad.gob.mx

Design and editorial production coordination: Bernardo Terroba Arechavala

Style review: Avril Carranza Kuster and Carlos Galindo Leal

Editorial design: Rafael Ríos Rodríguez

English translations: Karina Simpson, Mónica Álvarez Herrasti,

Adam Kent and Alcides L. Morales Pérez

Illustration design: Annamaria Savarino Drago and Rafael Calderón Parra

Cover Illustration: Annamaria Savarino Drago

How to reference:

Ruiz-Gutiérrez, V., Berlanga, H.A., Calderón-Parra R., Savarino-Drago, A., Aguilar-Gómez, M.A. and Rodríguez-Contreras, V. 2020. Illustrated Manual for Landbird Monitoring. PROALAS: Latin American Program for Landbirds. National Commission for the Knowledge and Use of Biodiversity / Initiative for the Conservation of the Birds of North America, Mexico and Cornell Laboratory of Ornithology Mexico City and Ithaca N. Y. 104 pp.

Edited in Mexico

Cornell Laboratory of Ornithology

The Cornell Laboratory of Ornithology is one of the world's foremost leaders in the study, appreciation, and conservation of birds. It is characterized by its excellent scientists and technological innovation to understand nature and engage people in learning about birds and protecting the planet. It was founded in 1915 and is a non-profit organization sponsored by 100,000 friends and members. The community includes 420,000 citizen science participants worldwide and 14 million enthusiastic birders of all ages.

CONABIO – NABCI

The North American Bird Conservation Initiative (NABCI) is an agreement among Canadian, US, and Mexican non-governmental organizations, academic institutions, and government agencies to facilitate and promote the conservation of all native birds of North America and the American continent and their habitats through internationally, nationally, regionally, and locally coordinated actions based on scientific knowledge. The national coordination of NABCI-Mexico has its permanent headquarters at the Commission for the Knowledge and Use of Biodiversity (CONABIO).

Contents

About this manual and how to use it	7
Why Monitor Landbirds?	9
Learning to Monitor Landbirds	11
Birding and monitoring equipment	11
Preparations for Landbird Monitoring (what to bring and how to behave):	16
Species identification	16
What is Community Landbird Monitor?	20
Landbird Monitoring	23
What is a monitoring program?	23
Latin American Landbird Program (PROALAS)	24
Protocol	24
How to enter data using the eBird Mobile App	40
How to create an eBird account	54
References	57
Glossary	59

APPENDIX 1	
Datasheet and how to use it	63
APPENDIX 2	
Step-by-step instructions for PROALAS	67
APPENDIX 3	
How to enter PROALAS data into eBird on the computer?	69
APPENDIX 4	
Individual and group accounts for PROALAS monitoring in eBird	79
APPENDIX 5	
Occupancy models	83
APPENDIX 6	
Merlin: A Field Guide on Your Cell Phone	95

About this manual and how to use it

CONABIO'S COMMUNITY MONITORING NETWORK is a citizen science project aimed at local communities. It was created in 2009 to monitor land birds and use them as indicators of the impact of management and conservation measures in agricultural systems, protected natural areas and biological corridors while learning about their distribution and population status.

The project's training activities followed the Manual for Community Landbird Monitors (NABCI/CONABIO). This manual has been successfully used in different regions and communities, in alliance with projects such as the Mesoamerican Biological Corridor of Mexico (CONABIO) and the Integrated Ecosystem Management project (MIE-CONANP).

Based on these experiences, and to strengthen the capacities and enhance the scientific value of the data (observations) of the community landbird monitors, the Cornell Laboratory of Ornithology and the NABCI-CONABIO Coordination developed the PROALAS protocols and this Illustrated Manual as a tool to unify landbird monitoring and conservation efforts in Latin America, through international cooperation, community participation, and intersectoral coordination. We hope that, with the implementation of the techniques described here, the fieldwork of community monitors will provide research-quality information on the status of landbird populations and, together with traditional knowledge, will help to establish measures for the conservation and sustainable use of natural resources, which will also favor the quality of life and community development.

This manual is intended for beginner and advanced birders, local guides, researchers, and anyone who wants to improve their skills in landbird monitoring.

The **Learning to Monitor Landbirds** section mainly aims at beginning birders in local communities but is relevant to any beginner birder and focuses on developing species detection and identification skills and learning about community landbird monitoring. The section on **Landbird Monitoring** focuses on making field observations using a simple and specific methodology, so more experienced monitors and birders will be able to study this section directly.

In the last part, the manual has a **Glossary** where the technical concepts used are explained and includes six **Appendices** containing information on mobile monitoring applications and the essential elements of occupancy models to simplify and facilitate fieldwork.

Why Monitor Landbirds?

BIRDS ARE AN ESSENTIAL COMPONENT of **ecosystems** because they perform vital functions for its maintenance and regeneration, such as seed dispersal and predation, pollination of many plants' species (including species of economic importance), regulation of insect and rodent populations (some of which are potential pests), and in the recycling of organic matter and carrion that help prevent the spread of diseases. In addition, because of their beauty and behavior, birds link us directly with nature, offering us a spectacle of colors and sounds that attracts millions of people to observe and photograph them as a recreational activity, generating significant economic revenue.

Most birds are diurnal and relatively easy to observe. They are a sensitive group of animals that respond quickly to changes in the environment, which makes them excellent indicators of the quality of the ecosystems. Given the above, monitoring and counting birds, using specialized techniques and methods, allows us to estimate the distribution and relative abundance of their populations, know their trends, and detect population changes in response to human activities, such as the application of management measures and restoration efforts in a natural protected area, changes in land use, deforestation, agriculture, and also natural phenomena such as hurricanes, fires or floods. Information from monitoring helps plan management actions and make informed decisions to conserve species and habitats.

On the other hand, we know that bird monitoring activities, including citizen science, can reconnect people with nature and the inherent value it holds, either as a recreational activity or for explicit research purposes, or by pure observation and understanding of the dynamics of the environment. More specifically, within citizen science, participatory or community monitoring helps strengthen land stewardship, the perception, and appropriation of nature and promote the involvement and

co-responsibility of communities and the participation of people in conservation and environmental education activities.

Bird monitoring is useful to:

- 1) Identify the **bird community composition**, their **habitats**, and their behavior at different times of the year.
- 2) Collect information used to determine which species are rare or at risk of disappearing.
- 3) Study **endemic** species and species of economic and cultural importance.
- 4) Build capacities for ecotourism projects focused on birding.
- 5) Determine relative changes in bird populations and species diversity due to management and conservation measures in natural protected areas, restoration regions, biological corridors, and productive landscapes (forestry and agriculture).
- 6) Evaluate the response of birds to changes in environmental conditions such as hurricanes, droughts, or fires.
- 7) Promote birding as a recreational activity in the community to foster the appreciation of birds in the wild.

Learning to Monitor Landbirds

THIS SECTION IS FOR PEOPLE with little or no experience in birding and identification and those who are interested in learning and participating as bird monitors in their local communities.

Birding and monitoring equipment

- Binoculars (8 x 42 is ideal)
- Field guide for bird identification
- Field notebook (to record observations)
- Pencils
- Watch (to record the start and end time of sampling)
- Smartphone (recommended)
- Camera (optional)

Binoculars

Binoculars are an essential tool for observing and identifying species. In addition to helping us see far away, they allow us to observe the distinctive characteristics of the species, such as colors, markings, and plumage patterns.

All binoculars are marked with two numbers separated by an x; for example, 8 x 42. The first number corresponds to magnification power, that is, how much larger an object appears relative to actual size. In this case, an object will appear eight times closer. The second number refers to the diameter in millimeters of the objective lenses (Figure 1), which determines the amount of light entering the binoculars. This is important because the larger the diameter, the more light enters and, therefore, the higher quality image is obtained.

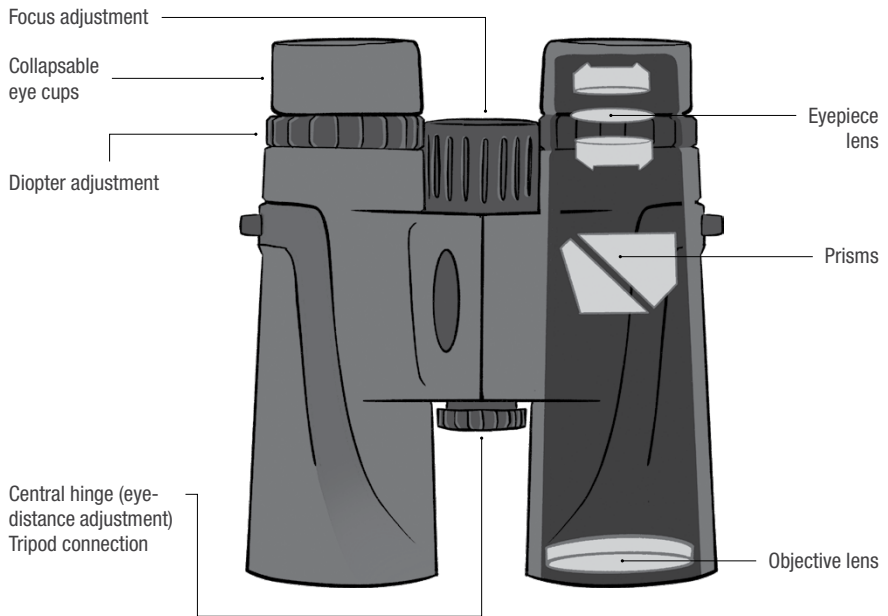

Figure 1. Names of the main parts that make up the binoculars.

NOTE

Although each observer should use the binoculars that best suit their needs, the most recommended size is 8 x 42 or similar, as they are comfortable, light, and versatile under different light and visibility conditions.

Diopter adjustment

Since almost everyone has better vision in one eye than in the other, it is necessary to compensate for the difference. For this purpose, binoculars have a diopter adjustment ring (Figure 1) that is used to adapt each lens to the vision of each user.

Diopter Adjustment Procedure

- 1) Adjust the width between eyepieces to your eye separation distance so that you see a perfectly circular image.

- 2) **If you wear glasses**, rotate the eye cups down so that your glasses can make contact with the lens (Figure 2 a).
- 3) **If you are not wearing glasses**, rotate the binocular caps to their highest position so there is a space between the lens and your eye (Figure 2 b).
- 4) Close the eye of the diopter adjustment side, and focus until sharp an object with your other eye. Then, open both eyes and move the diopter adjustment ring until you see the same object clearly. The diopter adjustment is only needed when we use our binoculars for the first time.

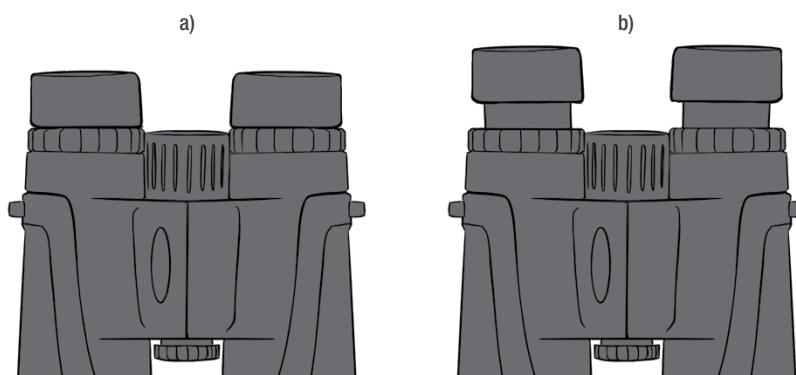

Figure 2. a) If you wear glasses. b) If you don't wear glasses.

Perhaps the biggest challenge for beginning birders is finding birds in vegetation and focusing on them in full motion, but this is solved with practice. Once you spot a bird, stare at it, and without looking away, place the binoculars in front of your eyes without moving your gaze. Look for the bird's movement in the field of view while turning the focus ring to get a clear image. Practice with other objects such as leaves or branches, and soon you will be able to do this movement naturally.

Care and cleaning

Binoculars are high-precision optical instruments and are therefore fragile. That is why it is essential to take care of them, avoid getting them wet (always carry

a plastic bag or their case with you), or leaving them in the sun. To avoid knocks or falls, it is always recommended to wear them around your neck or keep them in your backpack.

The lenses should always remain dry and free of dust or sand, as they can be permanently scratched. Binoculars should be carefully cleaned after each use. Remove sand and dust using a soft brush before using a soft cloth or microfiber. Finally, binoculars should be stored with their case in a safe, cool, and dry place when not in use.

Field guide

Field guides are essential for learning to distinguish and identify different species of birds. Various options are now available, usually containing illustrations or photographs of species from a region or country. Most describe each species' distinctive characteristics, and some point out the features that differentiate them from similar species.

It is always advisable to review the field guide, know its structure, leaf through it, and familiarize yourself with its contents before using it in the field. This will help you quickly find the species you are looking for, its description, or its distribution map. It is good to have several guides to complement the information whenever possible. Remember that not all the species in the guide may be found in our region. To avoid errors, it is essential to check the maps or descriptions of the distribution and habitat of each species (Figure 3).

In general, field guides indicate the birds' common and scientific names, and although the interests of observers may vary, we recommend familiarizing yourself with both names.

Species identification in the field is not always easy. Many species are unmistakable or very common and abundant, but others are rare or very rare, moving very high in the vegetation or silently on the ground; some have evident markings, but others have subtle or almost imperceptible differences that make them difficult to identify or distinguish from similar species, even for the most experienced birders.

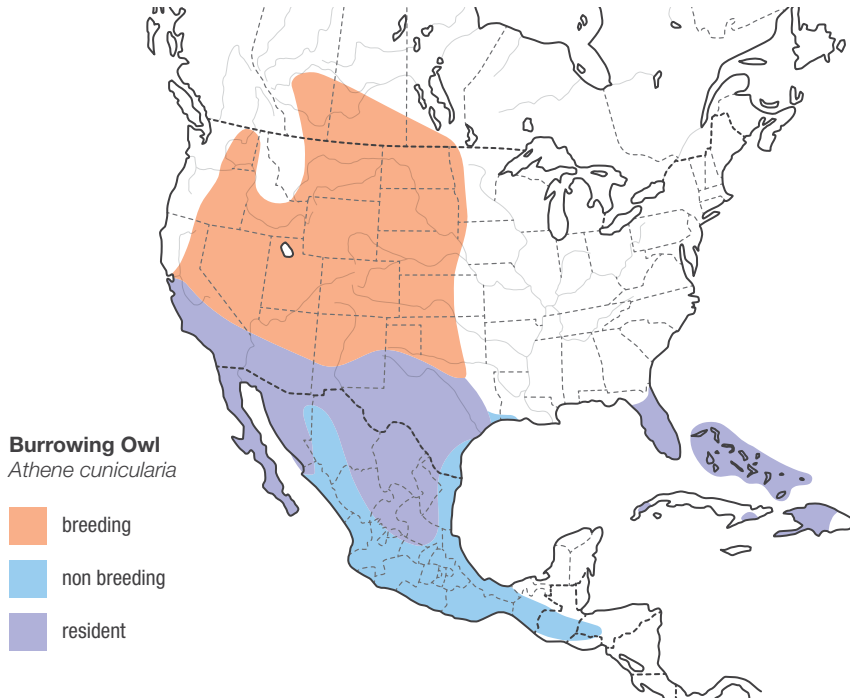

Figure 3. Example of a distribution map. The colors represent the time of year the species is present.

When you spot an unfamiliar bird, observe and memorize everything you can about it as long as it allows you to observe it: the size and shape of its body, tail, and beak, the colors and markings on its head, belly, or wings. Take note of where the bird is and what it is doing, whether it is alone or with other birds, and, when possible, pay attention to its calls or songs. It will be difficult at first, but you will gain the skill and confidence to identify species without problems with practice. If you have a camera or smartphone, taking photographs or audio recordings of an unfamiliar bird will allow you to share these with more experienced birders to assist in accurate identifications.

When visiting an area for the first time, it is recommended to consult existing lists, for example, on the eBird portal, and familiarize yourself with the species that have

been reported in the locality or monitoring area. You can also use Merlin from the Cornell Laboratory of Ornithology to get a list of all species for your area and time of year that you can use to familiarize yourself with using their song, calls, or different plumages. The Cornell Laboratory of Ornithology developed Merlin Bird ID, a cell phone application to help identify bird species from many countries or regions. The app is very easy to use, free, and available for iOS and Android phones. Please see Appendix 3 for further instructions on how to use Merlin. You can mark probable species with a pencil in the field guide to find them faster in the guide.

Preparations for Landbird Monitoring (what to bring and how to behave):

- Binoculars (8 x 42 or similar)
- Camera with a telephoto lens (optional)
- A comfortable backpack with your field guides, fresh water, and snacks
- Field notebook, pencils, and watch
- Smartphone (with the eBird and Merlin Apps installed) (recommended)
- Appropriate footwear and a cap or hat
- Discreetly colored clothing, preferably beige, khaki, or light green
- Open your senses, be attentive, walk slowly and quietly
- Do not get too close to the birds or their nests

Species identification

When observing a bird, you should pay attention to the following aspects (with practice, you will do it naturally):

General shape and size of the bird. This helps you to know what type of bird it is. A heron? A flycatcher? A duck? A raptor? Pay attention to proportions. For example: How big is the beak compared to the head? Or, how long is the tail compared to the body? What is the shape of the beak, wings, and tail? (Figure 4 e) What is its posture like? Is it upright? Horizontal?

Size. This characteristic can be misleading depending on the distance from the observer. It is advisable to take as a reference some object close to the bird (a leaf, a flower, a rock, a post) to compare and get a more accurate idea of its size. You

can also compare its dimensions with those of nearby birds whose size you are familiar with. For some species (for example, some herons and gulls) relative size is an important identifying trait.

Behavior. Each bird species usually has a particular behavior; in some cases, it is so specific that identification will be immediate. Observe what the bird is doing: how is it flying, is it singing, is it hiding in the brush or walking on the ground, how is it feeding, is it nibbling on a log, is it swooping to catch flies or eating among leaves, is it swimming or diving, is it gliding or flapping in flight? Observe the behavior and the place where the bird is, as this information is key to identifying the species.

Songs and calls. Some species are difficult to detect because they are shy, have dark colors, camouflaged plumage, or are nocturnal. Bird songs and calls will sometimes be the only way to identify that a species is present. On the other hand, some species look so similar that it is only possible to distinguish them by their sounds, as is the case of some tityras, Old World flycatchers, and tyrants. Birding with companions familiar with the songs of the region's birds will be of great help in fine-tuning your hearing. Constant practice and careful observation of which birds make which sounds are the key to developing the ability to identify species by song. Some websites and applications include a wide variety of bird sounds that will help you learn or corroborate, such as Merlin and Macaulay Library.

Colors. The color patterns on the body, beak, and legs are often the field marks required for correct identification. Pay attention to the head; what color is the eye, crown, nape, or back? Observe the chest and belly, the color and markings on the wings and tail. Search carefully for any particular spots, bars, or lines. Some of these aspects are essential to differentiate between similar species.

Habitat and distribution. Some birds live in specific ecosystems and may prefer particular vegetation types and a particular vertical stratification region. For example, the upper part of the forest or the ground. Others are generalists and are found in a wide variety of habitats. Where is the bird, what type of vegetation is it on, is it on a log, hiding in bushes, or in an open area? Look carefully, read the habitat descriptions in the guides, and check with the distribution maps (Figure 3).

Figures 4a to 4e show the names of each part of the bird's head, body, wings, and tail.

a) Lines and parts of the head

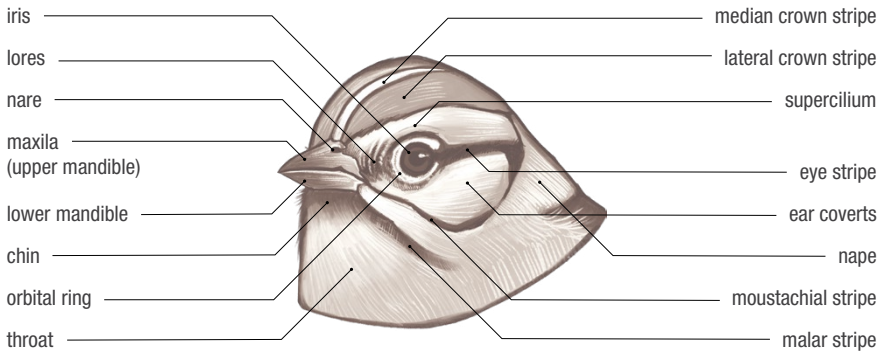

b) Parts of a bird

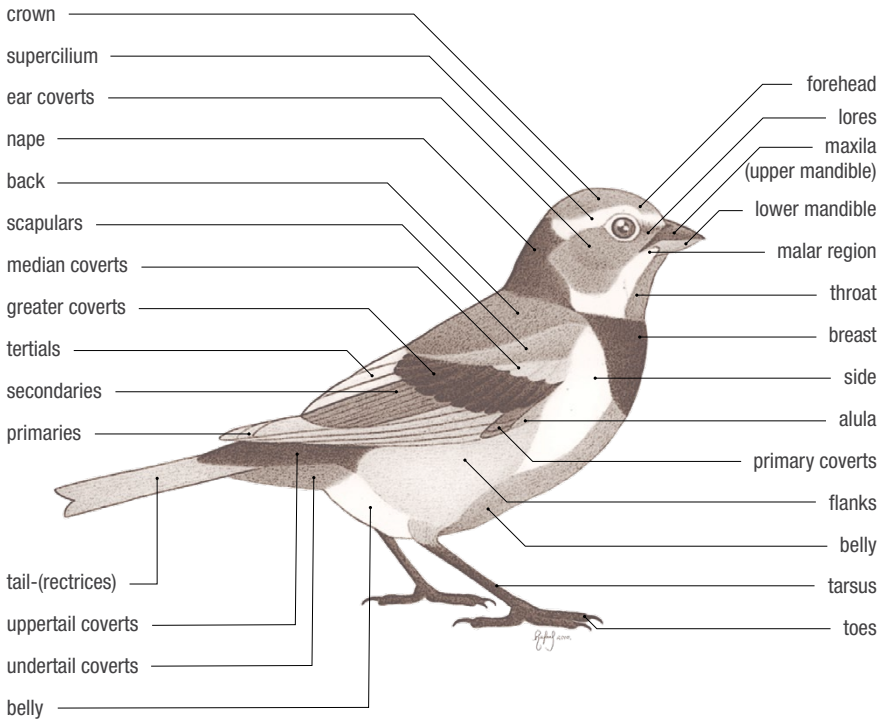

c) Hummingbird parts

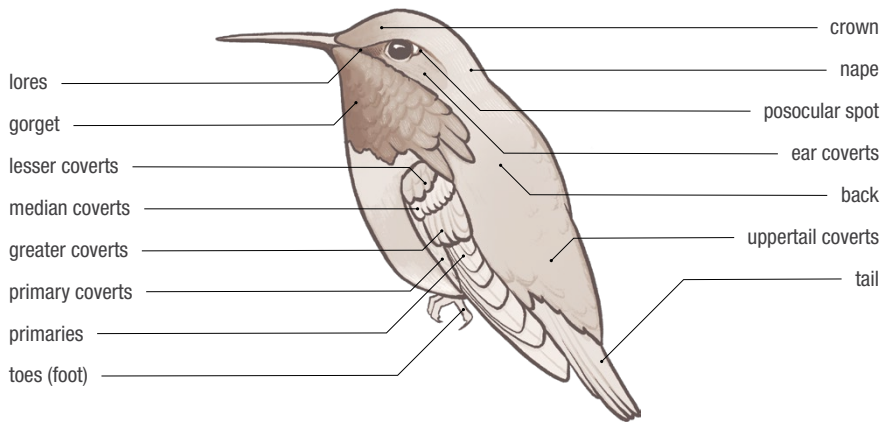

d) Parts of the wing

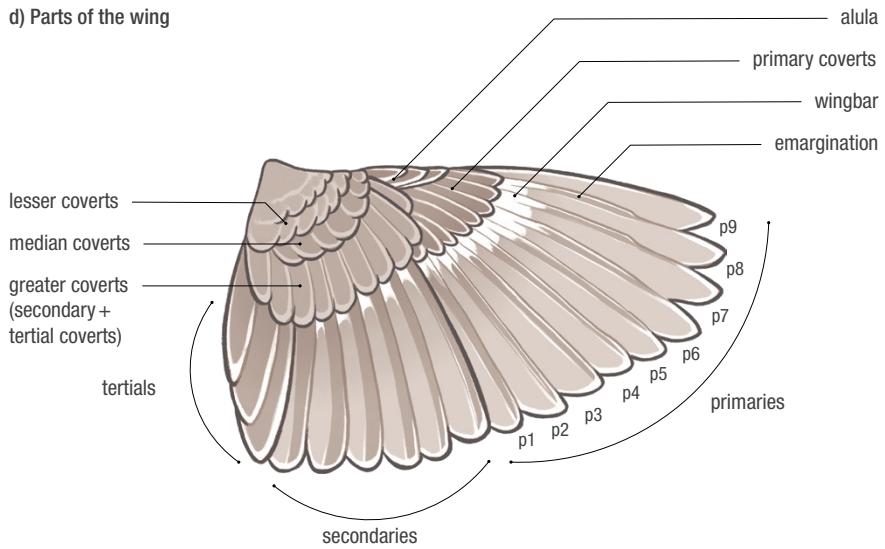

e) Some tail types

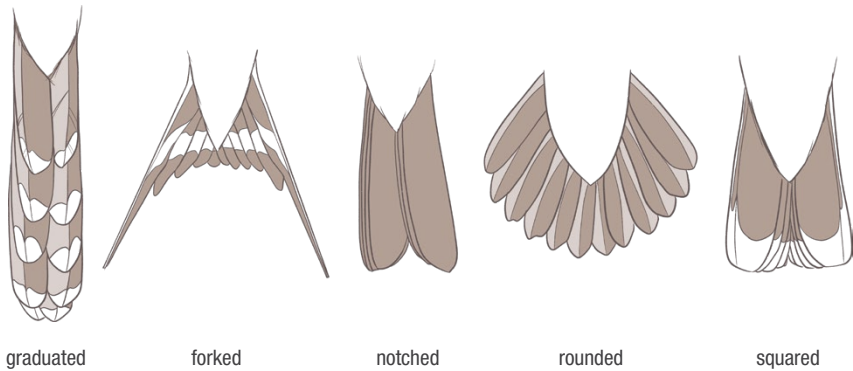

Figure 4. a) Lines and parts of the head, b) marks and parts of the body, c) topography of a hummingbird, d) parts of the wing, and e) some types of tails.

NOTE

Sometimes, even with all this information, it will be challenging to identify some species, so it is recommended that you write down their characteristics, draw or photograph them and then look them up in other field guides or ask for help from more experienced people. Other times you will only be able to identify the genus, and even then, it is crucial to keep the record and write it down in your list, for example, *Empidonax sp.* It is preferable to be honest and write down the genus or even the family if you are not 100% sure of the identification. Do not despair; with practice, you will be able to identify most birds at site, even just by hearing or seeing them fly. You will find that identifying new species will also become easier.

What is Community Landbird Monitor?

CONABIO's community bird monitoring network is a citizen science project aimed at local communities. It was created in 2009 to monitor land birds and use them as indicators of the impact of management and conservation measures in agricultural systems, protected natural areas, and biological corridors and learn about their distribution and population status.

What does it take to be a community bird monitor?

Anyone can become a community bird monitor. However, certain attitudes and aptitudes help make the learning process faster and more efficient, so it is desirable for monitors to have the following attributes:

- 1) Have a personal taste for nature and the countryside.
- 2) Be in good physical condition for long hikes, sometimes under challenging conditions.
- 3) Be interested in the conservation and management of nature.
- 4) Be committed to their community.
- 5) Be responsible and disciplined for fieldwork and for collecting data following strict protocols.
- 6) Have dedication and patience to study and learn the characteristics and names of the birds in their region.
- 7) Have enthusiasm and perseverance to improve their skills through constant practice.
- 8) Always have a good disposition with their companions and dedicate the necessary time and effort to monitoring activities throughout the year.

Landbird Monitoring

What is a monitoring program?

ECOLOGICAL MONITORING PROGRAMS ARE DESIGNED to gather information about the state of an ecosystem, population, or species, at different points in time. Systematic monitoring and tracking of state variables of wildlife populations allow us to answer specific questions of interest for management, use, and conservation decisions. For example, what is the richness of bird species in a coffee plantation or a forest plot? What is the relative abundance of a parrot population in a protected area? Are hawk populations able to use managed forests relative to undisturbed forests? What is the population trend of a given species and region?

Any monitoring project should be designed to answer specific questions, so before we begin, we should consider the following:

- 1) What do we want to know?
- 2) What information are we going to collect to inform our answer?
- 3) How, when, and where will we collect information?

Clear objectives, specific questions, and a field protocol establishing the criteria for choosing sampling sites, what effort is needed, what time of year we need to sample, what summaries we can generate, or what statistical models we will apply to our data. These aspects are essential for answering the questions posed, testing hypotheses, and identifying patterns and trends. This ensures the quality and reliability of the information to support decision-making or to answer other research questions.

In many parts of the world, there are monitoring programs that use citizen science data to detect changes in landbird populations, make comparisons between regions, and determine which sites, habitats, or areas are most important for the conservation of these birds.

Latin American Landbird Program (PROALAS)

PROALAS is a monitoring program designed to research and monitor landbird populations in Latin America. However, it is applicable to many landbird monitoring efforts since it uses a robust design approach that is amenable to many advances in statistical data modeling. It uses the eBird platform to compile, sort, and validate field data. The protocol is specifically designed to be analyzed using an occupancy modeling framework (Appendix 5). The PROALAS protocol is designed primarily to monitor resident and migratory landbirds, and protocols for monitoring other groups, e.g., waterfowl, will be incorporated in the future.

This protocol differs from others in two important aspects: 1) it is designed to maximize sample size at sites with high species richness, and 2) its design meets the requirements for data to be analyzed using accessible statistical tools, e.g., occupancy, abundance, and richness models (Jones 2011).

PROALAS is useful for:

- 1) Knowing the distribution of species.
- 2) Documenting the relationships between species and habitats.
- 3) Determining resource use by landbirds at different spatial and temporal scales.
- 4) Estimating relative abundance and population trends.
- 5) Evaluating the effect of management and conservation measures.
- 6) Evaluating environmental impacts and estimating ecological integrity.
- 7) Evaluating the impact of forest management strategies or agroforestry projects on the conservation of landbirds and biodiversity.
- 8) Evaluating the impact of sustainable agricultural projects.
- 9) Generating information for environmental and ecological certification schemes.
- 10) Facilitate the use of landbirds as indicators of ecological integrity.

Protocol

There are several ways to count birds. One of the techniques that PROALAS uses is defined sampling units such as **point count** or **mini-transects**. These sampling

units are established within a project's study region, for example, inside forest plots, covering the different habitats found in coffee plantations or within the core zone of a protected area. This method is versatile and adapts to different objectives and conditions. The protocol consists of **counting** and **recording** all birds seen or heard within a minimum of **10-minutes**, within a series of one or two distance bands.

Bird counting technique: Point Counts

2 Band Point Count

The first option is the **2-band** protocol. This option works well for semi-open and closed habitats where counting birds beyond 30 or 100 mts will not likely be helpful. For this protocol, you need to count all identified individuals within a minimum of 10 minutes within two bands, but you can count for longer as long as you record the exact time. On average, you will not need to go longer than 15minutes. The first band is within a 30-meter radius around the previously established, fixed point-count location. The second band is any area outside 30 m (Figure 5).

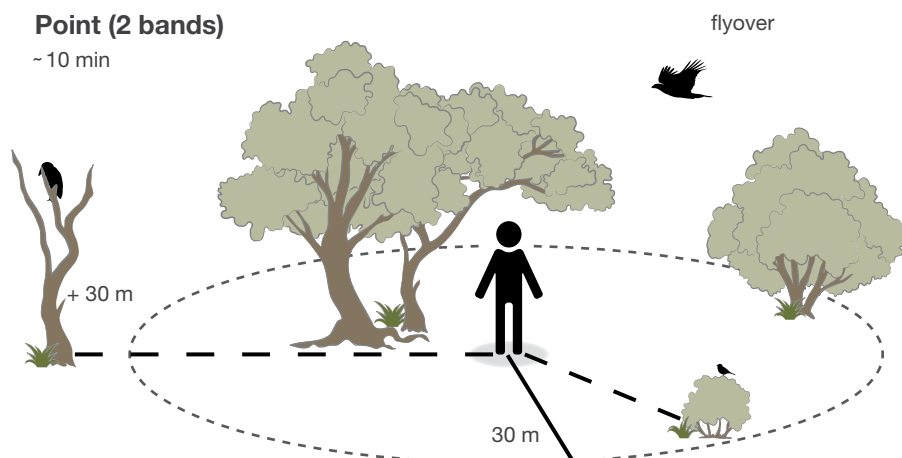

Figure 5. Dimensions of a 2-band point count. The space inside the circle is called the sampling area. The monitor should record all individuals of each landbird species observed inside and outside the sampling area within a minimum of 10 minutes. Birds flying over the circle should be recorded as Flyover.

3-Band Point Count

This option works well for open habitats, such as pastures or open fields, where you can easily see between 30-100mts and beyond 100mts (Figure 6). Other instructions are similar to those outlined above. In the 3-band point counts, it is necessary to record all birds detected within 30 m around the previously established, fixed point-count location, those detected between 30 and 100 m, and finally, those detected more than 100 m away. To establish whether 2-band or 3-band points will be used in the project, do not hesitate to write to proalas@cornell.edu or proalas@conabio.gob.mx.

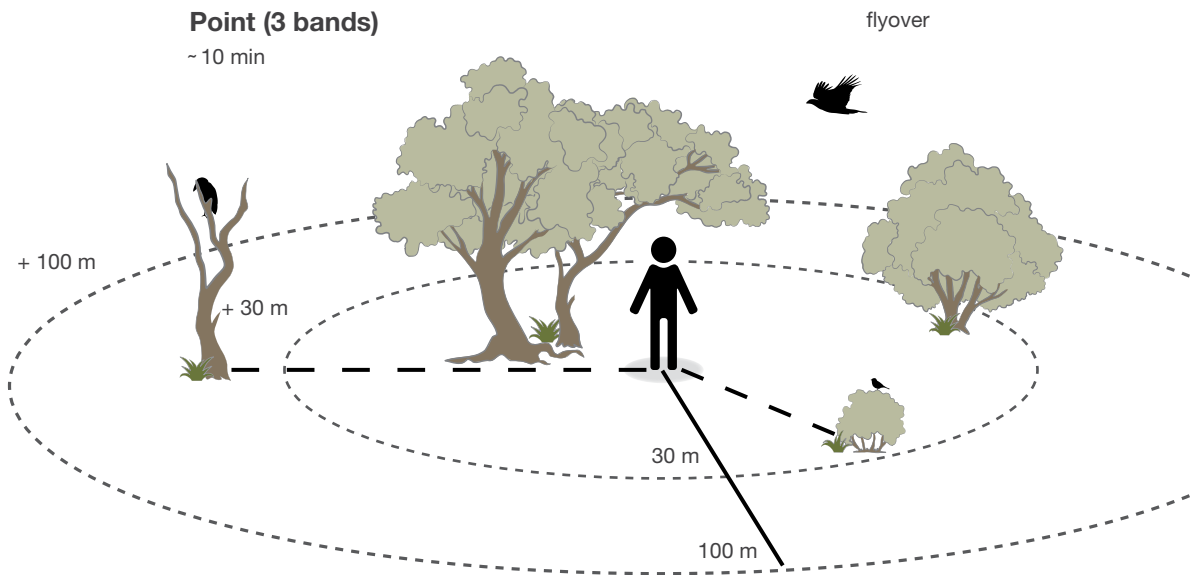

Figure 6. Dimensions of a 3-band point count. Birds flying over the circle should not be recorded.

Bird counting technique: Mini-transects

The protocol includes a third option of a mini-transect (Figure 7) in addition to traditional point counts. The transects work well for very closed habitats, where it is hard to observe or count birds within a restricted area of 30m. The transect should be 100 m long and 25 m wide on each side. This method consists of

walking at medium and constant speed along the transect, recording all the birds seen or heard. It is essential to record the birds observed as you go along and not record the individuals seen behind more than once. As with the point counts, you can leave the centerline of the transect to identify a species, but to continue, you must return to the centerline.

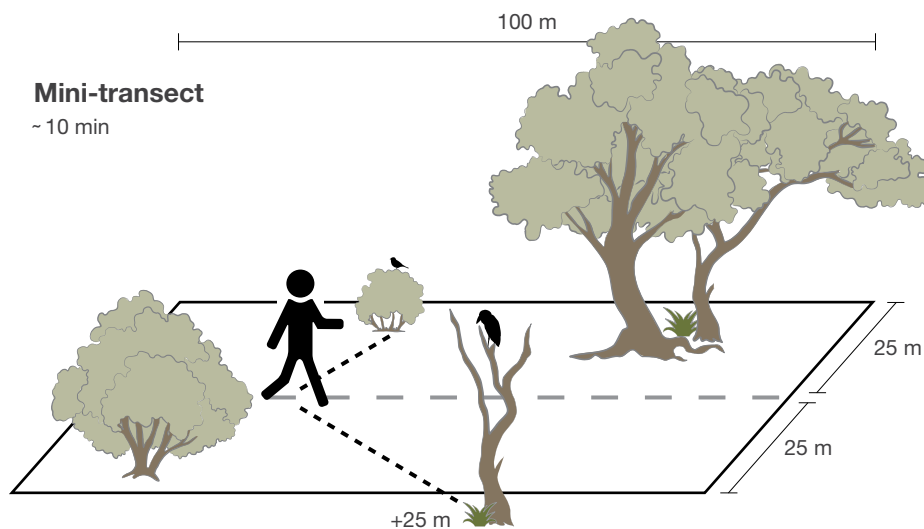

Figure 7. Dimensions of a counting transect; we call the entire space within the rectangle “sampling area.” The number of individuals detected inside and the number observed outside the sampling area should be recorded.

How to count and what to record?

When you arrive at an established count location, use the eBird app, the data Spreadsheet provided on **Appendix 1** or your notebook to mark the start time of the count and record all individuals of each species observed within a minimum of 10 minutes or longer when bird activity is high. Count the number of individuals of each species within each band, using the band where the individual was first detected. Some individual birds will move around within the count area during the 10-minute count. It is essential to include that individual in the tally for the band in which the observer first detected it. In the end, note the end time of the count for

each point or transect, or if using the eBird app, stop the checklist. Go to the “How to enter data using the eBird Mobile App” section for instructions on using the app.

To improve the accuracy of the observation distance, you can use marks or references in the field to estimate the distance inside and outside the point count circle. **It is important to note all individuals of each species that are seen or heard inside and outside the distance bands.**

If necessary, you can move around inside the sampling area to identify species. Still, you should always return to the center to differentiate between birds inside and outside the area. At each point, start a new list and repeat the procedure. Again, all individuals of each species should be noted, regardless of whether they were also seen at the previous point or on the way from one point to another. For example, if two individuals are observed outside the distance bands during the count but then move to the location of the next point, they should be counted in both points.

Flyovers: Some individuals fly over the sampling area without stopping. Record these individuals, specifying that it is a ‘flyover’ to ensure it will not be included in the analysis.

Species	Within 30m	Outside 30m
6:13, Start ZOHLG-001		
<i>Amazona albifrons</i>	1	1
<i>Colaptes rubiginosus</i>		1
<i>Ramphastus sulfuratus</i>	1	1
<i>Phaethornis longirostris</i>	1	
<i>Henichorina leucosticta</i>	1	
<i>Campylopterus hemileucurus</i>	1	
<i>Basileuterus culicivorus</i>	3	
<i>Setophaga pensylvanica</i>	1	2
<i>Myarchis tuberculifer</i>	2	
<i>Hylocichla mustelina</i>	1	
<i>Euphonia gouldi</i>		2
7:23, End ZOHLG-001		
7:30, Start ZOHLG-002		
<i>Aulacorhynchus prasinus</i>	1	1
<i>Cardellina pusilla</i>	1	
<i>Chlorospingus flavopectus</i>	2	
<i>Pheugopedius maculipectus</i>	1	1
<i>Ramphastus sulfuratus</i>		1
<i>Psarocolius montezuma</i>	1, F	
7:45, End ZOHLG-002		

Figure 8. Example of data recorded on spreadsheet. Note the last record, *Psarocolius montezumae*, is a flyover marked with an F.

In this spreadsheet example (Figure 8), in both points 1 (ZOHLG-001) and 2 (ZOHLG-002), *Ramphastos sulfuratus* was recorded; in point 1, a total of 2 individuals were detected (1 inside and 1 outside the sampling area), while in point 2, only 1 individual was seen outside the sampling area. *Psarocolius montezuma* was recorded as a Flyover.

NOTE

To avoid errors and make an efficient sampling, it is vital to make sure of the following:

- 1) Always visit the same points. It is recommended to place a visible mark that allows easy location (Figure 10).
- 2) Do not change the location of the points from one year to the next.
- 3) Make several replicates (repetitions) for each point count in each sampling season.
- 4) If you observe a notable species between one point and the next you want to record, write it down and upload it to your eBird account as an incidental record. This record should not be included in the PROALAS points. Remember not to take too long between points not to disrupt the continuity of the sampling.

How to locate the point counts?

It is necessary to identify the main types of vegetation or land use types that exist in the project site area. The study area selection needed to define the count locations will depend on the specific objectives of each project.

The following table provides a simplified description of the **main types of vegetation or land uses** that you can use to describe the locations where you will be monitoring:

Vegetation Type	Land Use description
Cultivation/crop	Agricultural areas. They may be sugar cane fields, cornfields, coffee plantations, plantations, among others.
Pasture	Open areas with few trees, dominated by exotic grasses where livestock is raised (cows, sheep, etc.).

Vegetation Type	Land Use description
Urban	Areas associated with critical human settlements include cities, towns, and urban parks. They are characterized by houses, buildings, and paved streets.
Secondary vegetation	Disturbed areas in the process of natural regeneration, such as <i>acahuales</i> , burned sites, abandoned pastures, orchards, or disused agricultural land.
Reforestation and restoration areas	For example, forest plots, reclamation, or revegetation sites with native plants.
Borders	Describe, for example, the boundary between a pasture and forest or forest patch.
Rainforest	These are lush, tropical plant communities characterized by tall trees (30 meters or more) that keep their leaves all year round, with many lianas, epiphytes, and palms.
Dry forest	Low or medium-sized, diverse jungles dominated by trees less than 15 meters high, which lose their leaves during the dry season. They develop in hot climates with scarce and seasonal rains.
Cloud forest	They are diverse plant communities dominated by tall trees with several strata, with a great abundance of epiphytes and ferns. They develop in high areas with abundant rain and cloudiness all year round.
Coniferous forest	Forests dominated by pines, <i>oyameles</i> , and frequently oaks. They develop in mountainous zones with temperate to cold, humid, or dry climates.
Oak forest	Forest dominated by oak (<i>Quercus</i>). They grow in the middle and lower part of mountainous areas, often mixed with pines.
Scrubland	Low vegetation communities, commonly dominated by thorny shrubs, leguminous plants, and cacti, that usually grow in lowland areas with dry climates.
Grassland	Open areas dominated by grasses and shrubs, with few trees.
Desert	Dry and open areas, characterized by very little rain and extreme temperatures, sparse vegetation, and sometimes dominated by cacti.

Vegetation Type	Land Use description
Wetland	Bodies of water such as rivers, lakes, lagoons, swamps, mangroves, marshes, and flood zones.
Coast	Beaches, dunes, and coastal vegetation.

Example:

If the objective is to know how many species of landbirds are found in a region, a specific location, or a protected area, it will be necessary to locate points in as many types of vegetation or land use identified in the area.

To set a point count or mini-transect, do the following:

- 1) Within your study region, define accessible routes that you can easily walk to, and consider that you can likely only monitor 10-12 count locations during a morning. Remember to place points so you sample the habitat of interest in its entirety.
- 2) Establish a minimum distance between each count location (to reduce the possibility of counting the same individuals). The following table specifies the minimum and recommended distances for the location of sampling points in the field:

Category	Minimum distance	Recommended distance
Distance between points	200 m	200 m
Distance to a path	100 m	200 m
Distance to a road	200 m	200 m
Abrupt vegetation change	50 m	100 m

The number of count locations within the study area depends on the specific objectives of the monitoring. Overall, it is recommended to establish at least 20 count locations per vegetation type or land use (minimum effort). Whenever possible, avoid locating counts in sites that are difficult to access to facilitate fieldwork.

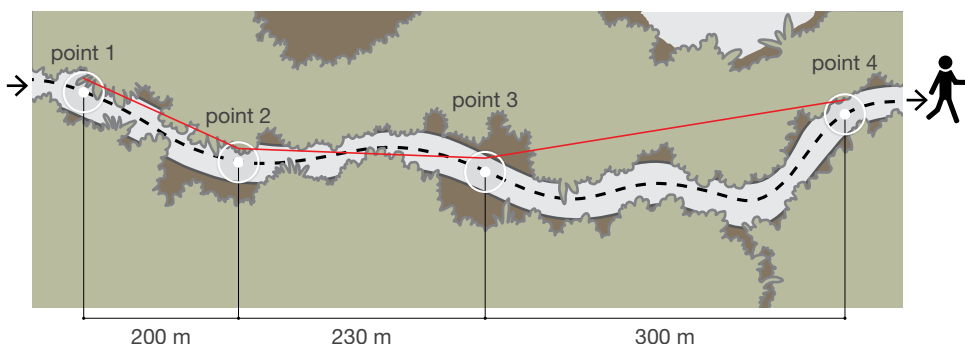

Figure 9. Example of a correct location between points considering a minimum of 200 m. Note that the dotted line route represents a winding road. The distance between points can be variable as long as it complies with the 200 m minimum.

Recording of points/transects

If you are using the eBird mobile app to record and enter information, you can skip this section. Each sampling point or mini-transect transect will be counted and entered into eBird separately, so each sampling location must have its geographic coordinates and a unique name.

Coordinates: These should be taken at the center of the point count using a GPS or smartphone. For transects, the coordinates should be recorded at the beginning and end of the transect. Coordinates can be noted using latitude/longitude in decimal degrees since these are simpler to process for uploading data to eBird).

Name: Assign each count location a short name describing the locality and point number.

Example:

For a first point in the community of Zoh-Laguna, you can assign the name: ZOHLG – 001.

Marking the points/transects: To mark each count location, you can place a label on a cut and stretched aluminum can or use a plastic tape or ribbon to put the point's name (Figure 10). You can also locate the points using your smartphone or GPS where you have the coordinates already marked.

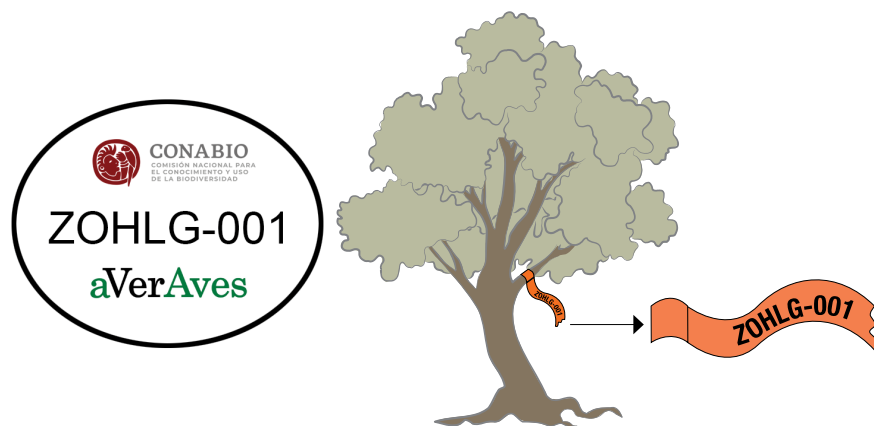

Figure 10. Example of how to permanently mark the points. The decal has the logo of the sponsoring institutions. The point key indicates the location (Zoh-Laguna) and the point number (001). You can also use ribbons or slats with the name of the point/transect.

Differences between points and mini-transects

All the recommendations for the points apply to mini-transects (minimum distances between the sampling units, monitoring, efforts, and how to register the points in the eBird platform). The main difference lies in being able to walk through the center of the transect instead of observing from a central fixed point during the 10-15 min. The distances of 25 m and 30 m should be practiced depending on the observation method. The coordinates of the transect to be recorded correspond to those of the start, but a minimum distance of 200 m between the end of the transect and the next point or transect must be taken into account (Figure 11). Remember that you can write to proalas@cornell.edu and proalas@conabio.gob.mx to ask for advice on the design of your project.

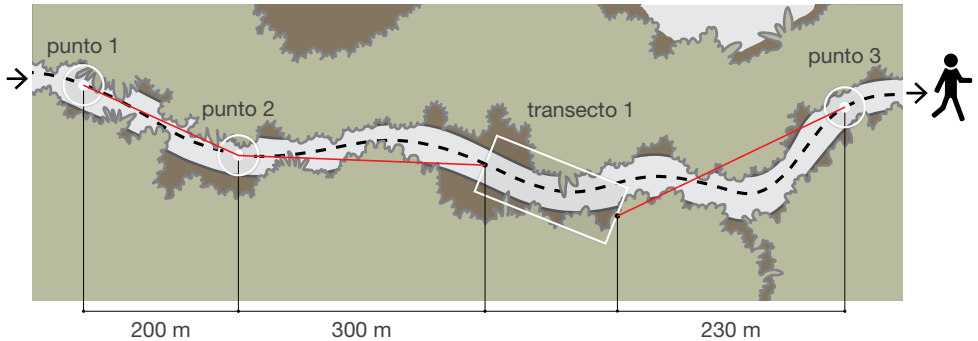

Figure 11. Example of a correct location with both points and transects with the minimum distance of 200 m.

When to use points and when to use transects?

Transects are recommended when sampling very closed habitats such as jungles and dense forests. These sites tend to have high diversity, but low bird density, and the transects can maximize the sample size. For open or semi-open areas, the point counts will work well. Point counts and transects can be combined in a single project depending on the type of habitat surveyed. It is essential to clearly specify whether the count was point or transect-based and to respect the minimum distances between each count.

Replicates. Why visit a count location several times?

If a birder visits the same place many times, they will realize that there are species that can be observed every time or almost every time they go because of the abundance, color, or behavior of the species. They will also notice that there are other species that are observed only one out of ten visits because the species is not very abundant, silent, or shy, are more difficult to observe or hear. Therefore, for the monitoring effort to be reliable and to be able to record most of the species present in a site, it is necessary to make several visits to each point or transect. Each of these is called a **replicate**.

Each point count visit is considered a replicate when multiple visits are conducted at a specific point count or transect within a two-week period. This period is called **season or pulse**, and the set of replicates per season is called a **round**. Replicates must be made within a season because it is assumed that in a short period (in this case, two weeks), the site (series of point counts or transects) and the bird community will remain relatively stable and unchanged.

NOTE

Each season's ideal number of replicates per point is 4-8, but sometimes 2-4 is enough. See the **Monitoring Effort** section for recommendations.

There are several ways to obtain replicates depending on the number of monitors participating in the fieldwork. Each one is explained below:

- 1) **Consecutive days:** A single person can visit each point for two mornings to obtain two replicates for each point.
- 2) **Offset:** A person can visit each point two times on the same day, i.e. monitor the points back and forth on the same route, and produce two replicates for each point.
- 3) **Simultaneous:** Two monitors can go, independently in one morning, to visit each point once (with a difference of at least 20 minutes between each one), and will also produce two replicates for each point. In the case of three people, three replicates would be obtained, and so on. If each point is also visited back and forth, the number of replicates will double in a single morning (Figure 12).

Example:

One person visits each point for three consecutive days (three replicates), or three people conduct independent counts at the same points (three replicates) and back on the same day (6 replicates). In either case, replicates should always be conducted within two weeks to maintain the season assumption.

Monday

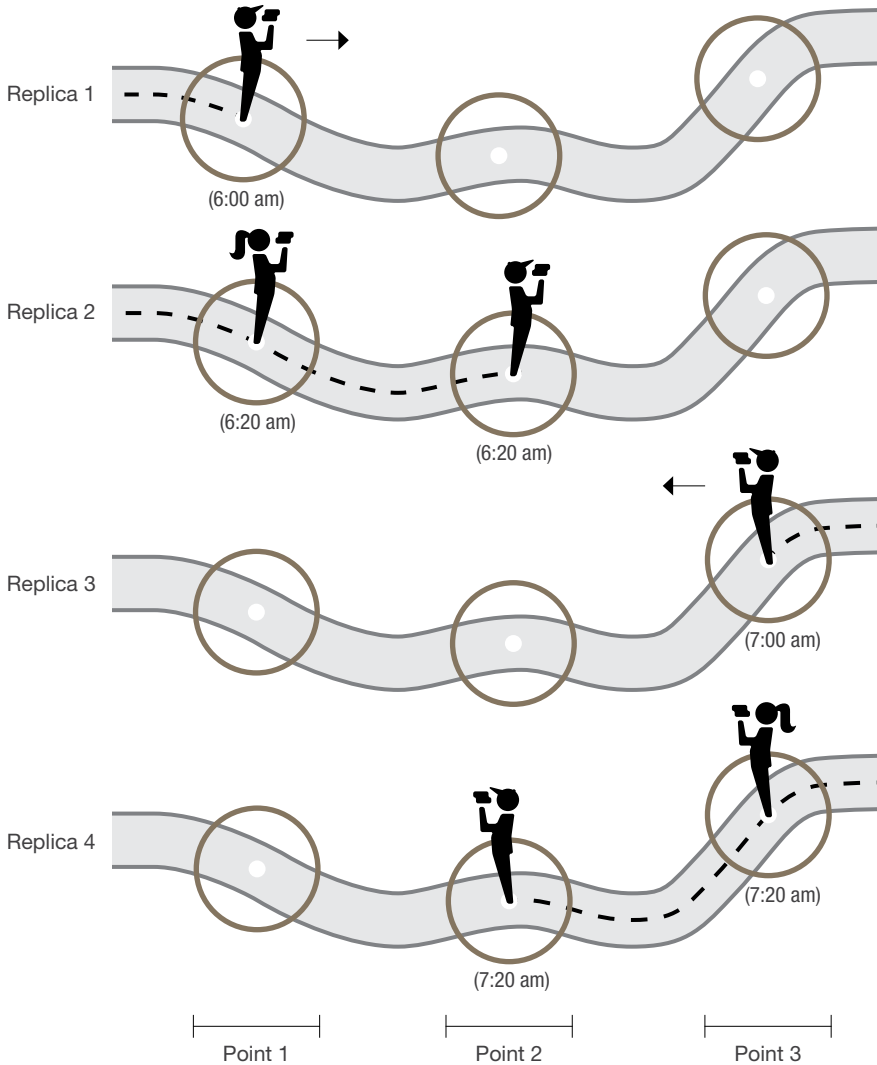

Figure 12. How to obtain replicates from two people in the field: at 6:00 am, the first person starts the monitoring route, followed by the second person 20 minutes later. Returning along the same trail, the process is repeated, which will generate four replicates for each point in a single day.

When to conduct the counts?

The time of visit, location, and the number of counts depend on the project objectives and extent of habitat. It is necessary to identify how the year's seasons affect the factors we want to measure or compare. For this purpose, in each season chosen, around should be made, that is, have 2 or more replicates or visits for each count location made in a period of no more than two weeks (in this way, at least 2 replicates are obtained).

Example:

If the objective is to know what species of landbirds are found in a community and when they breed, it is advised to make the point counts sampling efforts every three months to include the year's four seasons and cover the migration seasons.

In Mexico, four seasons are recognized: Autumn migration (August-November), winter residence (December-February), spring migration (March-May), and summer residence (June-July). Thus, one round should be conducted for each migration season, although the ideal would be once per month if complete information is desired.

Monitoring effort

The following table shows the minimum effort we should dedicate to monitoring to obtain reliable results and the recommended effort to get optimum quality results. Take this into account when designing your monitoring project.

NOTE

If you have questions about this or any other issue related to monitoring, do not hesitate to contact proalas@cornell.edu or proalas@conabio.gob.mx to receive help and advice to define the number of points, to upload them (register) in the system, and to determine when to carry out field surveys.

Aspect	Minimum	Recommended
Number of replicates	2 replicates in the same week	4–8 replicates in the same week
Sampling season	1 round of replicates per season (example: Dry vs. rainy season)	1 round of replicates per month
Weather	Days without rain	Days without rain, without fog, and with little wind
Counting time	10 minutes	Between 10 and 15 minutes
Record of birds in the sampling area	Record only the birds within the sampling area	Record the birds inside and outside the sampling area
Bird species registry	Particular group of species of interest	All species

Organization

People who have just been trained in landbird identification are not quite ready to carry out this monitoring. They should practice until they are familiar with the birds expected on site. It is recommended that the observer be familiar with using binoculars, know the field guide very well, and practice whenever they have the opportunity.

Counting protocols such as PROALAS require observers to identify and count birds efficiently and accurately.

If the monitors don't have access to smartphones with the eBird app, it is advisable to collect data manually using Notebooks and the Datasheet provided in Appendix 1. The following organizing procedure is recommended for a team of monitors during fieldwork, particularly at the beginning stage:

- 1) **Monitors** record data in their field notebooks.
- 2) **The monitors**, once at home, transfer these notes cleanly to the datasheets.
- 3) The **coordinator** compiles the datasheets.

- 4) The **coordinator** enters the information into the computer and sends it to the assessors (for example, NABCI-Mexico).
- 5) The local **assessors** return the revised records to the coordinator with the necessary comments to enter them into the eBird platform.
- 6) The **coordinator** enters the records to the eBird platform.
- 7) The **coordinator** communicates to the monitors the comments made by the assessors to their respective records to improve their skills.

The group **coordinator** must be a very active person and will be in charge of the most significant number of tasks, so he or her requires the support of all the monitors. To be a coordinator, it is desirable:

- 1) Have frequent contact with the monitors.
- 2) Have basic knowledge in the use of computers (Excel and internet).
- 3) Have a telephone and internet connection.

Using the eBird app on your phone will make the former procedure much easier. Whenever possible, it is highly recommended that each monitor have a personal eBird account and upload their observations directly through the eBird application (available free for iOS and Android) or a computer. This way, the coordinator will only be in charge of verifying that everything is in order. Instructions for using the eBird mobile application for the PROALAS program can be found the nest section: How to enter data using the eBird Mobile App. If you use your eBird account, you must use the function to share the lists generated during monitoring to your local PROALAS group account, which will send your records to the coordinator for review.

Registration of points/mini-transects in the eBird platform

The first monitoring visits entered into eBird for a point or transect will create and register these points and/or transects for future use. If you are entering data into a field sheet, you need to record the points/transects in another way:

1. If the coordinates of the points/transect were already taken using a GPS, you could fill out an Excel format with the name of the points and their coordinates, as shown in point 2. Once the form is filled out, it should be sent to **proalas@cornell.edu**. You will then find the points officially registered in the platform as PROALAS sites, and you can select them in your subsequent monitoring.

- The following example shows four hypothetical points located in the town of Zoh Laguna, Campeche, in Mexico.

	A	B	C	D
1	Name	Latitude	Longitude	Program
2	ZOHLG001	17.06948	-96.774871	PROALAS
3	ZOHLG002	17.07389	-96.802657	PROALAS
4	ZOHLG003	17.07152	-96.500627	PROALAS
5	ZOHLG004	17.05562	-96.55687	PROALAS
6				
7				

How to enter data using the eBird Mobile App

If you have a smartphone with an iOS or Android operating system, you can download the eBird application for free and enter the PROALAS monitoring lists directly into it. The application allows you to instantly record the birds seen inside and outside the distance bands of the point-counts or mini-transects and share the list with colleagues or the group account. For instruction on uploading PROALAS checklists on the eBird site with a computer, go to Appendix 3.

NOTE

Although the application is designed to work in the field without an internet connection, the internet is required to download and set up the app (and for sending the lists); pay attention to the following instructions before going out to the field. Please note that if you do not have an eBird account, you will need to create one, and for this, you will need an email address. The instructions and screens shown are for Android phones; the interface and some options may vary for iOS devices.

Download the App

To download the eBird application, first, go to the Google Play Store or iOS App Store application and search for “eBird,” the first option to display is “eBird by Cornell Lab,” click on the name of the application and then on “Install.”

Application start

Once the app is installed, you must activate it by logging in with an already created account (Figure 13 a). In case you need to create an account, the app will direct you to the eBird website (Figure 13 b), in the following section **How to enter PROALAS into eBird on the computer?** you will find instructions to create your account.

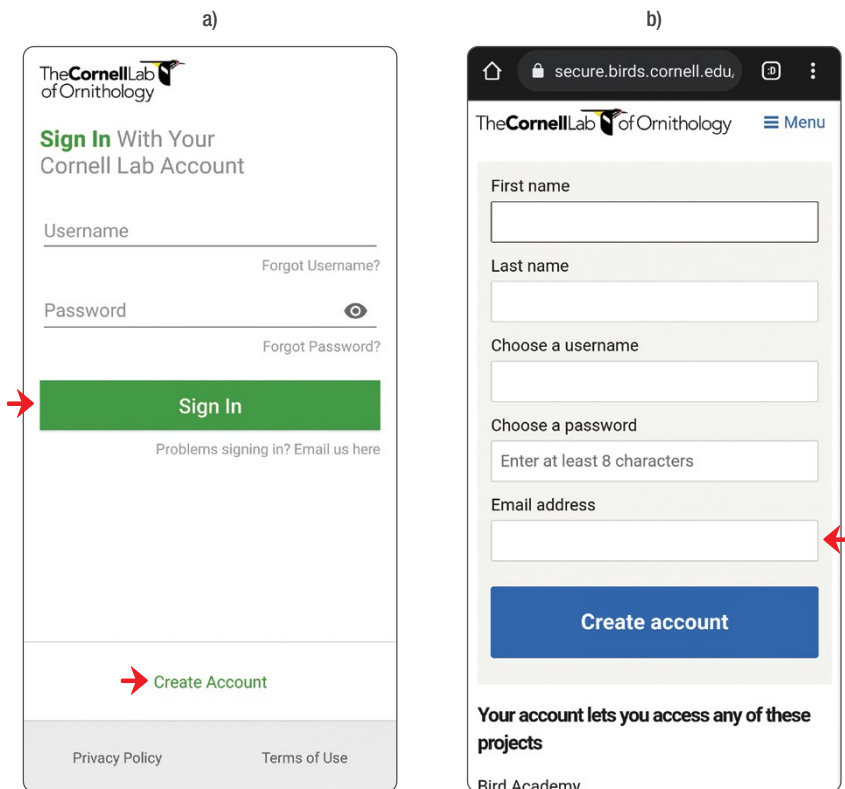

Figure 13. a) Start screen of the app, decide between “Sign in” with an already created account or “Create account.” b) If you need to create an account, enter the requested information (an e-mail account is required).

Settings (Species name display)

Once logged in, you will have to define some settings (Figure 14 a and b). It is essential to do this step before going to the field because the app comes pre-loaded with the names in English; therefore, to change the language, an internet connection is required, as the app will download the bird names in the language you choose. We recommend showing both scientific and common names. Click on the language to select the one you prefer for your common name display.

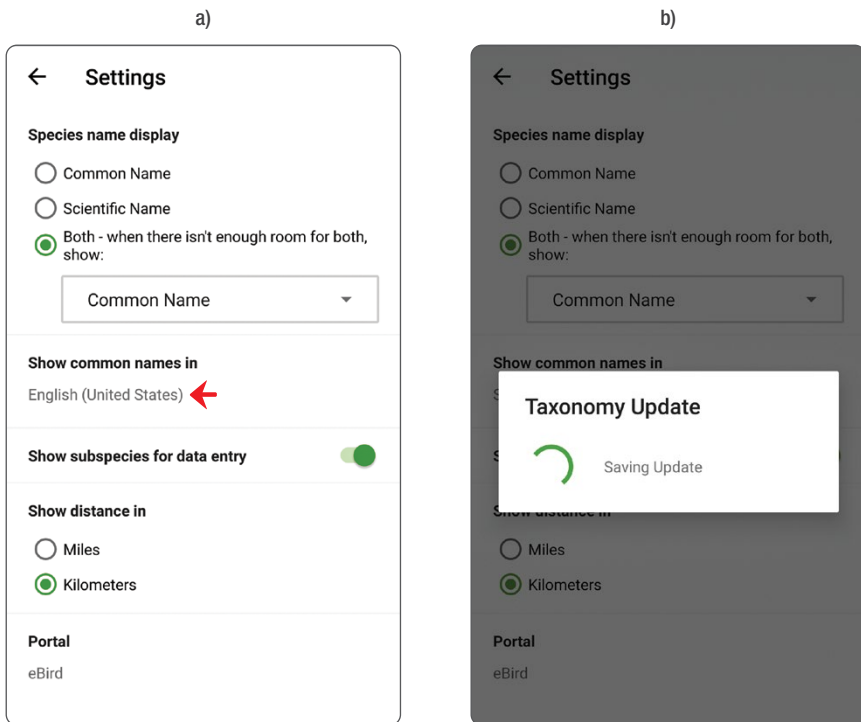

Figure 14. a) Settings, click on the language to change it.
b) Download names; this step requires an internet connection.

Downloading packages

The eBird app and platform offer lists of likely birds defined by location and time of year; this helps users find the species they observe much more quickly. We must install a package for our country to have these lists of possible birds. Please note that this step also requires an internet connection.

- When the app is installed, and the GPS is turned on, the app will automatically suggest a package according to the region you are on (Figure 15 a). You can also look in the “packages” section of the menu in the upper left corner of the screen, where you can browse through the suggested, installed, or all possible packages (Figure 15 b).

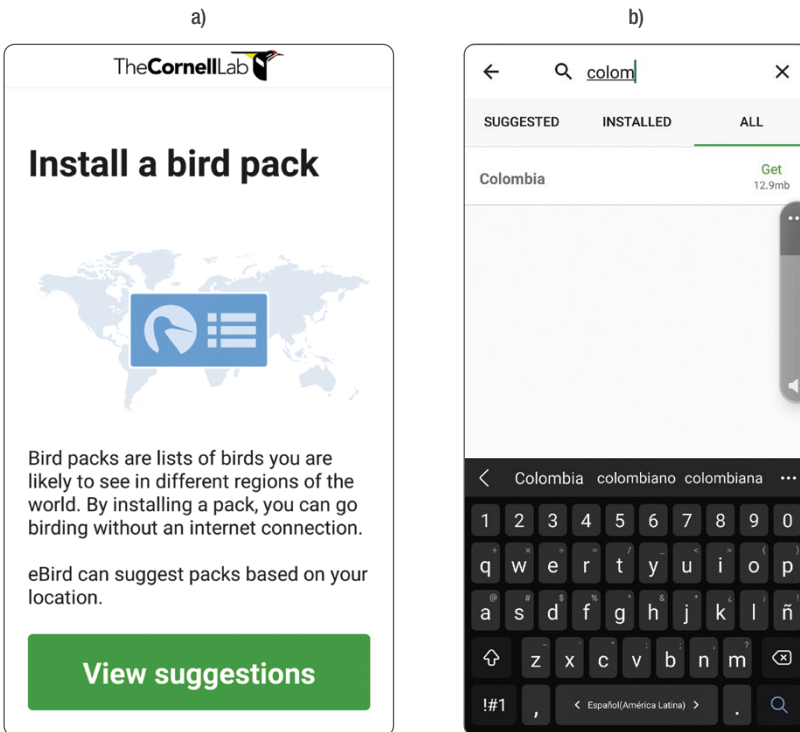

Figure 15. a) Package automatically recommended for our location.
b) Search for a package among all available.

Starting a Checklist

Once logged in, chosen a language for the common names, and downloaded a package, you're ready to start monitoring using the app.

It is common to have no internet connection in the field, so the following instructions are listed according to that assumption.

- Once in position for monitoring, open the app and select Start Checklist (Figure 16 a). The app will use the phone's GPS to locate the position; be sure to turn it on before starting (Figure 16 b).

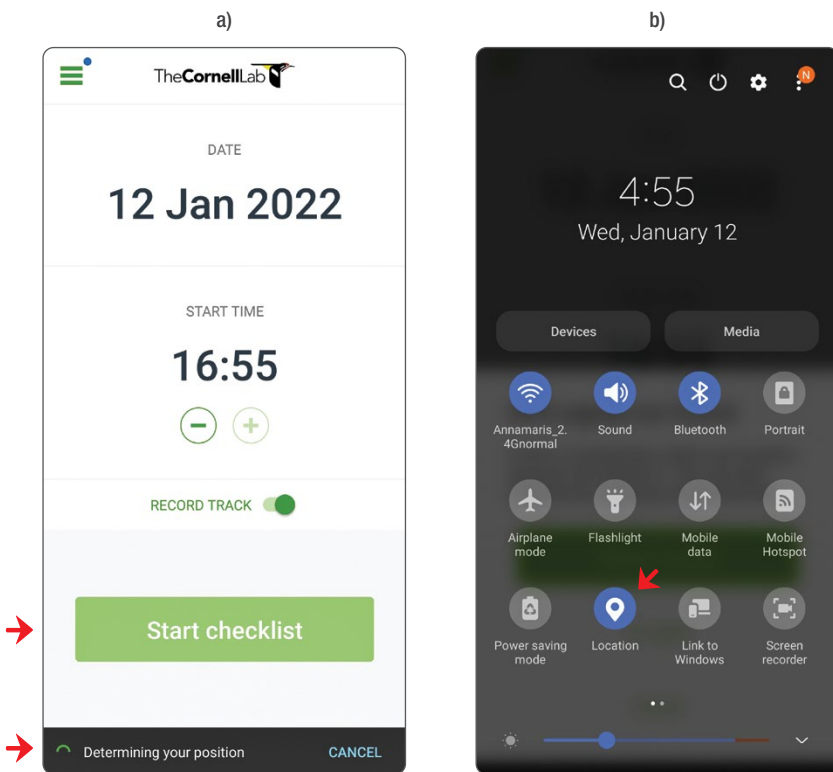

Figure 16. a) Screen to start a checklist; the app will automatically take the date and time of your device. b) Make sure to turn on the GPS, each phone has differences, but you can find this option in all devices by pulling the menu at the top.

- If the app has problems locating the current coordinates, it will throw a warning window that says: “GPS signal not found.” Check that the GPS signal is indeed on and click **Try again** (Figure 17 a). If you are in a remote area or with very high and dense vegetation, it is more likely the device will have trouble finding the signal, and you will have to repeat this step.
- If the problem persists, there may be a problem with your device, so it is advisable to perform a test list as soon as the app has been activated and check that everything is in order. If you cannot start with the GPS, click **Choose a bird list**, and you will be able to select a list for the country you have downloaded (Figure 17b).

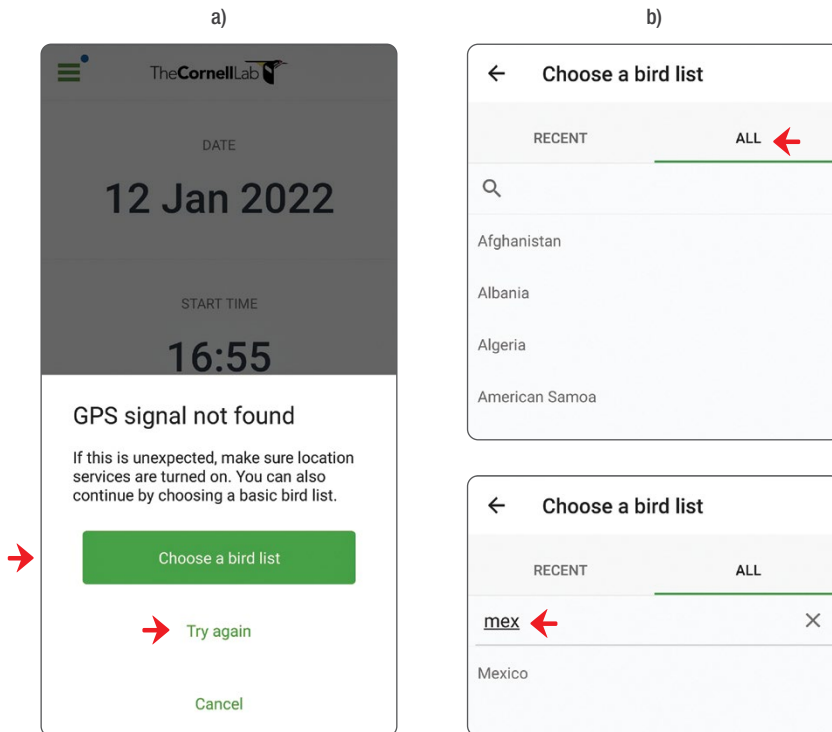

Figure 17. a) Warning “GPS signal not found,” make sure to turn on the GPS signal and, if necessary, click “Try again” a couple of times; sometimes the signal is not good. If you fail to start, use the “Choose a bird list” option. b) The All tab where you can choose your country list; example with Mexico.

- If you use the package for a country, the list of all probable birds for that country will be displayed. Such an extensive list can be confusing and impractical, so it is best to perform all of the above steps correctly before going out in the field, where you will not be able to get help. If you have used the app before and already submitted bird lists for nearby locations, you could choose from “Recent” lists, which will display a list based on locations already monitored.

Complete a list of birds

Once you have chosen a region or started directly with the GPS, the app will offer you a list of species to mark the birds you observe.

- At the top, you will notice that it will appear: “Auto selected” along with the coordinates where you started (Figure 18 a). This is a provisional name for the location; when you have an internet connection, you can specify the site’s name or choose a previously created location (for example, an already monitored point count).
- Before you start registering species, be sure to click on the 3-bar symbol on the bottom menu, this is the “Checklist settings” window (Figure 18 a and b). PROALAS is only available for some eBird portals: eBird, aVerAves (Mexico), eBird Caribbean and eBird Central America. Click on “Portal” and select the one that corresponds to your region. If you are not sure which portal is right, choose eBird (Figure 18 b).
- On the same menu, click on “Observation Type” and choose either PROALAS Point Count (2 bands), PROALAS Point Count (3 bands) or PROALAS Mini-transect according to your protocol (Figure 16 c). The two steps are important because they allow the eBird checklist to register species as PROALAS requires.

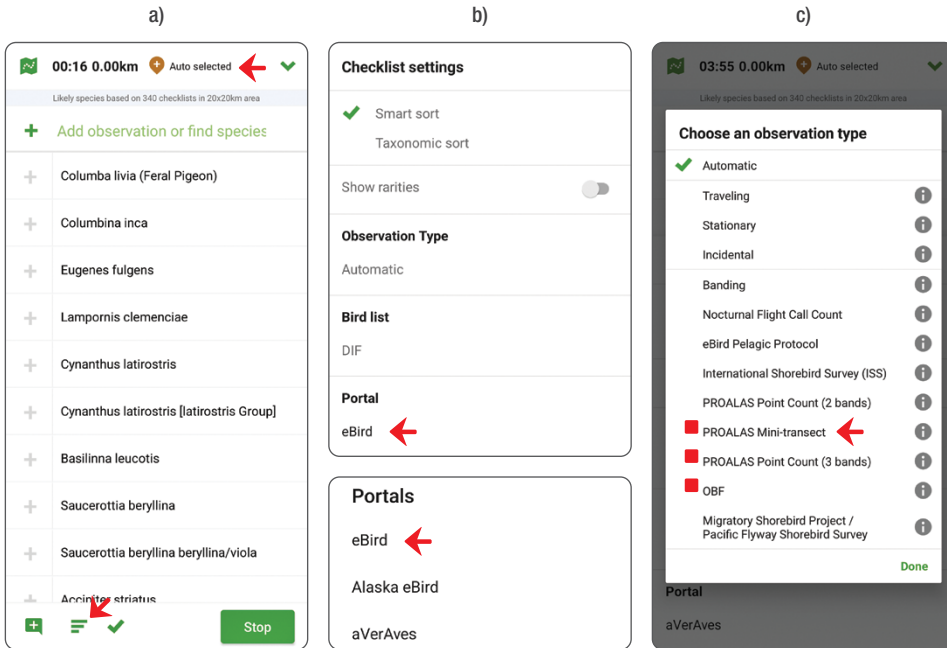

Figure 18. a) Species entry window with Auto selected site and Checklist setting location. b) Portal menu. c) Observation type menu with PROALAS protocol listed.

- Each time you click the + symbol located to the left of a species name, you will increase the number of registered individuals recorded one by one (Figure 19 a). As long as a species has 0 individuals assigned, you will see the + symbol replaced by the number of individuals registered.
- If you click the checkmark symbol located at the bottom of the list, you can display a list reduced to only the birds you have observed so far at that point or transect (Figure 19 a).
- To find a species in a long list faster, you can search for the species name in the top bar with the magnifying glass icon. You can use either the bird's common name or a four-letter code consisting of the first two letters of the genus, followed by the first two of the species (example: for the *Passer domesticus* species, the code will be "pado"). This code works for both scientific and common names (Figure 19 b).

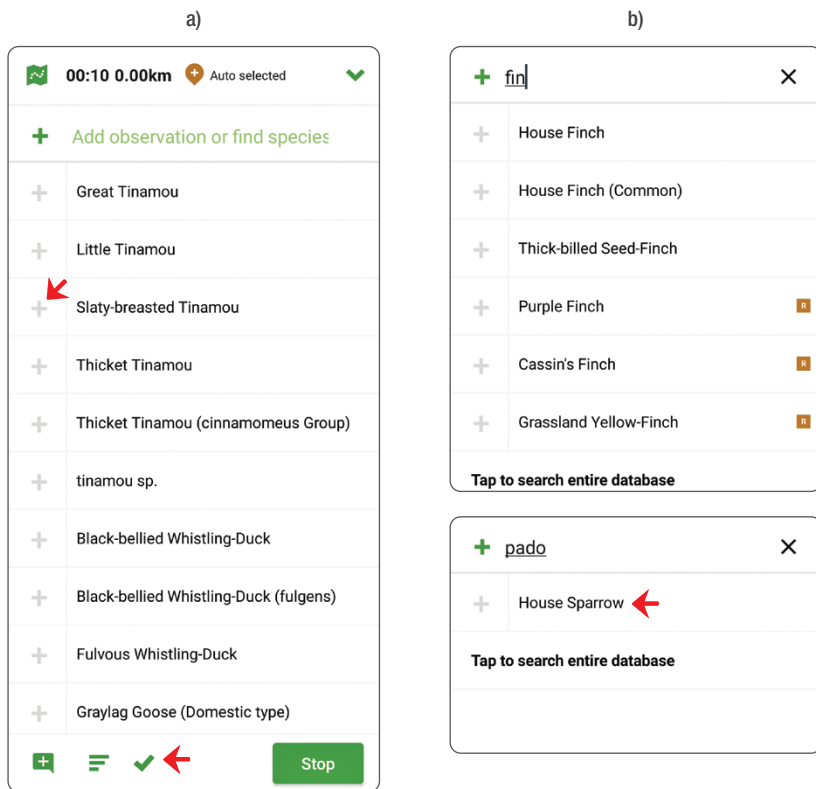

Figure 19. a) Species entry window with the quick-search bar, boxes to add individuals, and a checkbox for the species registered so far. b) Species search by common name (Example: House Finch) and species search by four-letter code of the scientific name (Example: *Passer domesticus*).

- By tapping on the name of a species, you can open a window to enter details of the observation (Figure 20 a). In this window, you can modify the number of individuals for that species, access the Merlin app (see Appendix 6), assign a reproductive code, or enter a comment. Make sure always to click **Done** to exit the box. Otherwise, the changes made will not be saved.
- To enter PROALAS information, locate the **Distance Bands** on the same window. Click the + symbol to register individuals seen “Within 30m” or “Outside 30m” (for a 2 band point count). For a 3 band point count checklist, a third slot will appear for “Outside 100m” (Figure 20 b). It is possible to

detect all individuals outside de point/transect. See examples on Figures 20 a and b of different scenarios.

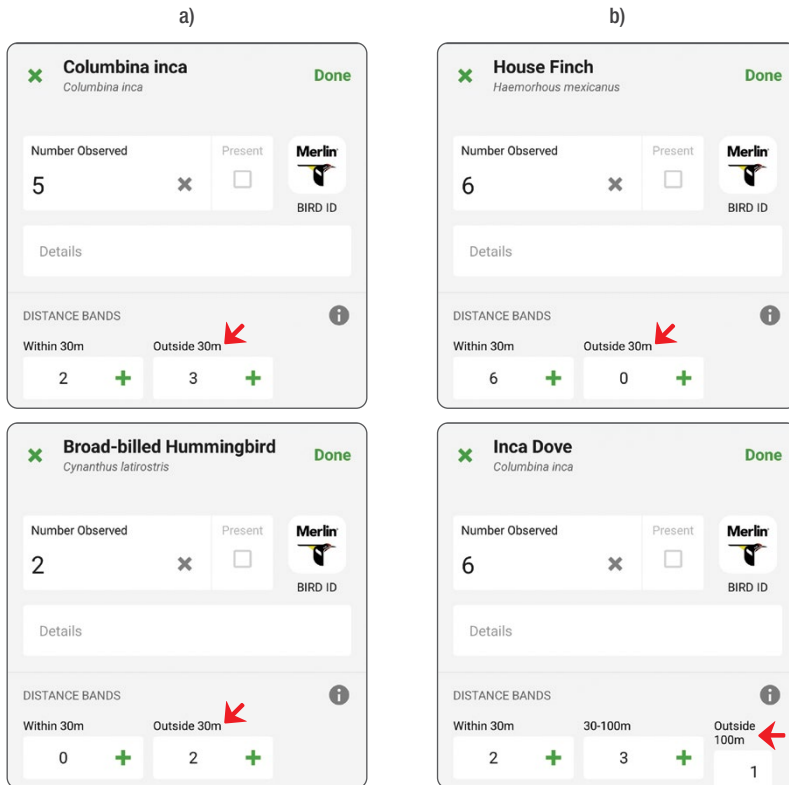

Figure 20. a) Comment window for specifying individuals seen inside and outside the point/transect. b) Examples of combinations of individuals inside and outside different types of points.

- Once you finish observing, click the **Stop** button, followed by **Stop Track**, when the “Are you done birding?” window appears (Figure 21 a).
- You will then be prompted to review the species list (Figure 21 b), eliminate possible errors, and add details. Make sure the portal and observation types are correct and correspond to the type of PROALAS protocol

made. If there is missing PROALAS information or an inconsistency in number of individuals registered, the record will appear orange with a warning sign reading “Distance band totals are incomplete” (Figure 21 b).

- Add or modify the number of observers, modify the count duration in minutes if needed and appropriately answer to the question “Are you submitting a complete checklist of the birds you were able to identify?” (Figure 21 b). Check your list carefully; it is common to mark birds by mistake with your finger.
- In the comments box, write the names of the monitors.

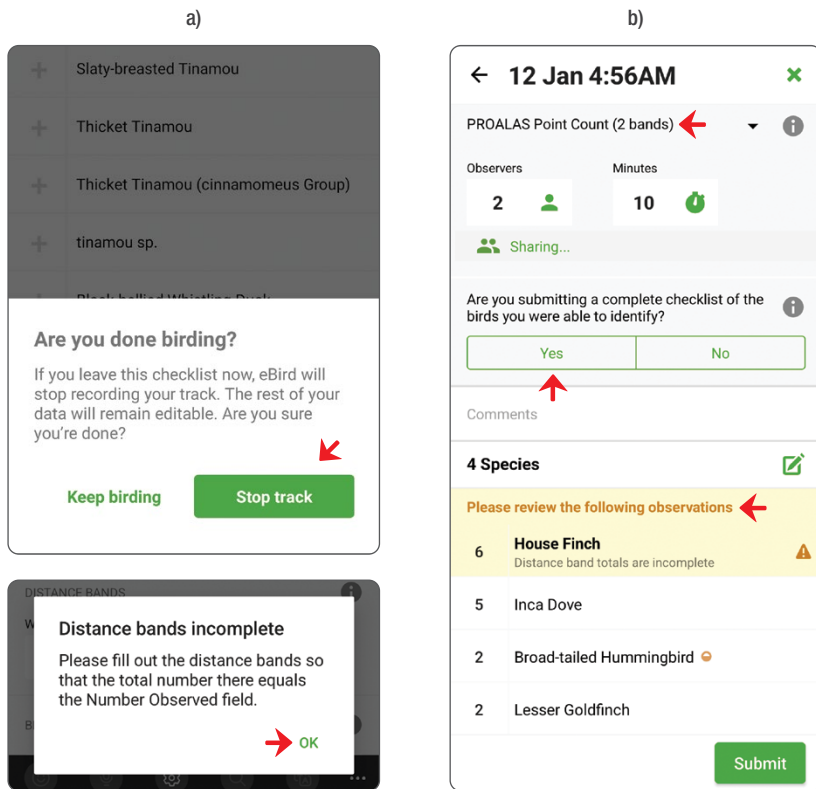

Figure 21. a) Stop track window at each point/transect and b) window to review the details of the list. Note warning sign upon missing PROALAS information.

NOTE

Up to this point, you will be able to perform all the steps without an internet connection. When you click Submit (Fig 22 a), the app will request you choose a location, if there was none chosen before. Note that you can select from 'Recent' while not having an internet connection, though this will only work after submitting previous checklist on the same point/transect. In order to fully submit a checklist, you will need internet connection.

If you are still in the field and continue making transects or points, click de **X** symbol on the upper right corner to close the list (Fig 21 b). You will be redirected to **Start Checklist** screen to start a new point/transect. Your lists will be stored even if you do not submit them; you can review them at any time by clicking on the Checklists icon (Figure 22 a) of the bottom menu and submit them (Figure 22 b) once you have an internet connection.

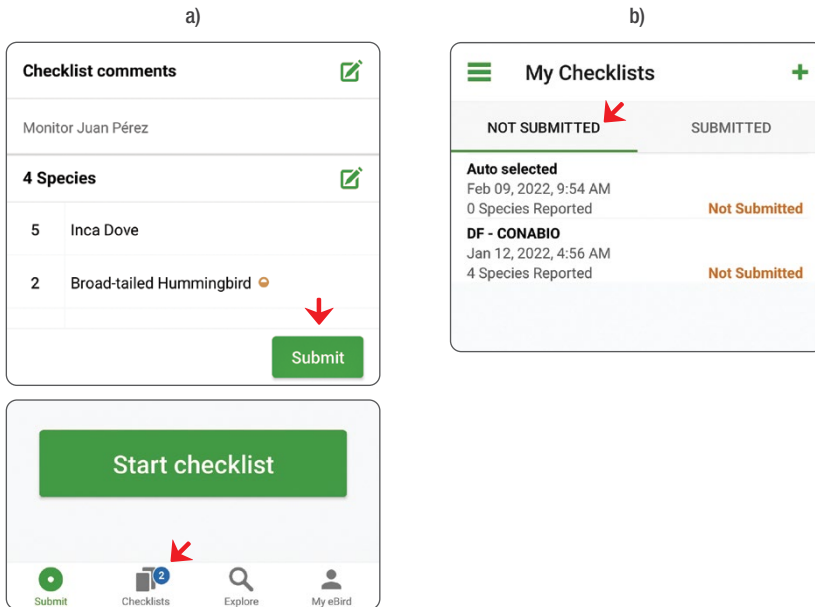

Figure 22. a) Submit button at the end of checklists icon. b) Not submitted checklists tab.

Sending a list (with internet connection)

- With your Review Window open, tap on **Choose a location...** located just below the Date and time (Figure 23 a). The “Select Location” window will appear with two tabs: “Recent” and “Nearby”.
- If you have registered and monitored the same point/transect it should appear on the **Recent** tab (Figure 23 a). Select the point or transect name correctly.
- If the point has not been registered yet, zoom in on the exact location on the map from the **Nearby** tab. Tap on the screen to create a “New location” and **Rename** it according to your PROALAS code name. You can also provide the coordinates on the search bar with the magnifying glass if you have this data. (Figure 23 b).

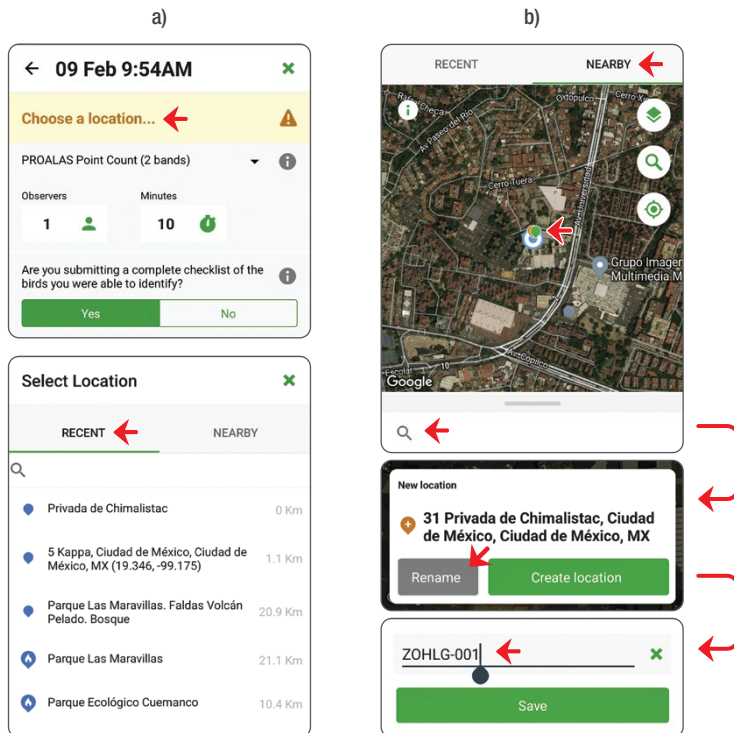

Figure 23. a) Select location option and recent tab.
b) Nearby tab with map and how to rename a custom point.

- Once you have chosen your location correctly, you will then be returned to the review window (Figure 24 a).
- To share your list with other monitors and with the group account, tap on the **Observers** bar to match the number of accounts the list will be shared with (Figure 24 a). At least two observers are needed to activate the Sharing window. Then, click on **Sharing...** and type either the eBird usernames or emails associated with eBird account of each person (Figure 24 b). Be sure to click “**Done**” to close the Sharing window correctly with all usernames promptly written; otherwise, these will not be saved. Whether you use the web portal or the mobile app, it is essential to share with the group account to record the information in both accounts.
- By clicking on **Submit** (Figure 24 a), your checklist will be uploaded to eBird. You can review and modify Submitted checklists on the **Checklist button** from the main menu (figure 22 a), this will require internet connection too.

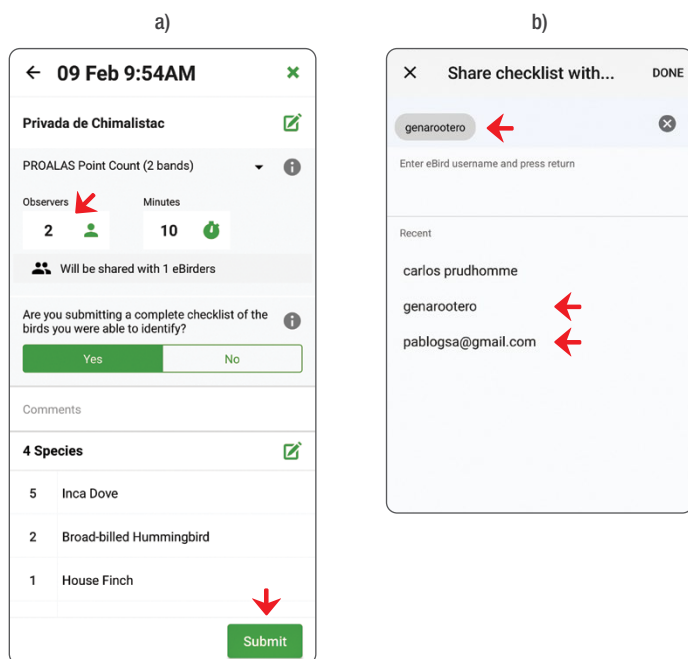

Figure 24. a) Submit button at the end of checklist review and Observers bar
 b) Share checklist with... window. Examples of usernames and emails written to share.

NOTE

It is advisable to register all the points/transects beforehand, so the previous process can be more agile. See the instructions on the Protocol section.

Any eBird user can view the records sent to the platform. Explore and know all the tools available to see the data! More than 500,000 users, 40,000,000 lists sent, and 10,500 registered species globally.

How to create an eBird account

It is always preferable for each monitor to have a personal account; however, for practical purposes, you can open a group account where you will enter the information of all the monitors in the group. In any case, each account requires an e-mail address (you can also open one for group use) so the platform reviewers can contact you if necessary (you will have to check it periodically). Here are the four steps to open an account:

- 1) Log in to the **eBird** website: <http://ebird.org/>
- 2) Click on the **My eBird** tab (Figure 25) or click on the green **Create an account** button.

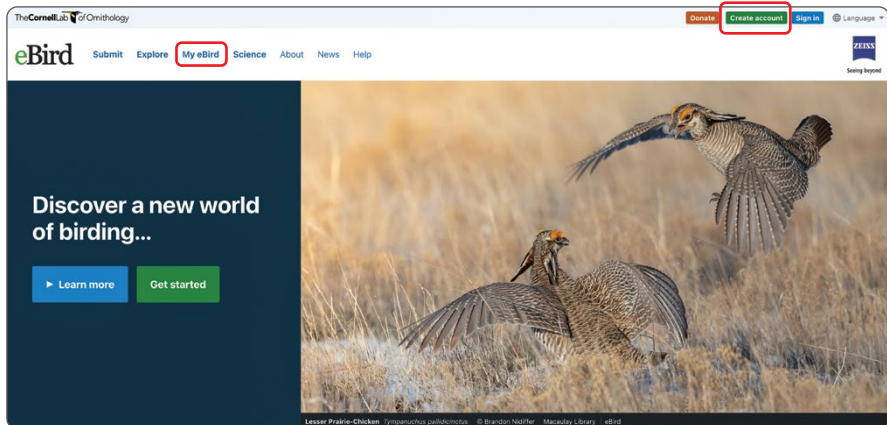
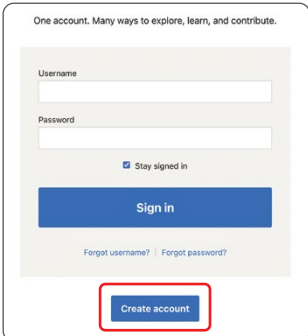

Figure 25. Location of “My eBird” and “Create an account” tabs.

- 3) Click on the **Create account** option (Figure 26 a).
- 4) Complete the following fields (Figure 26 b):
 - a) *First name and Last name (s):* name of the person or group.
 - b) Email address: the one previously created.
 - c) *Choose a username:* create one of at least 6 characters.
 - d) *Choose a password:* create one that includes at least 8 characters; type it again in “Confirm password.”

It is imperative to write down the username and password in a notebook and keep it safe to remember if necessary.

a)



One account. Many ways to explore, learn, and contribute.

Username

Password

Stay signed in

Sign in

[Forgot username?](#) | [Forgot password?](#)

Create account

b)

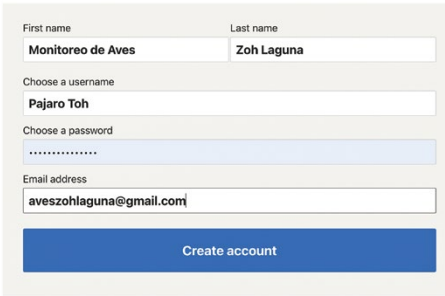

First name
Monitoreo de Aves

Last name
Zoh Laguna

Choose a username
Pajaro Toh

Choose a password
.....

Email address
aveszohlaguna@gmail.com

Create account

Figure 26. a) Registration window to enter the account. Write the “Username” and the “Password.” Click on the “Create account” option if it is a new account. b) Required fields to create a new account.

References

- Archaux, F., Pierre-Yves H., y O. Gimenez. (2012). When can we ignore the problem of imperfect detection in comparative studies? *Methods in Ecology and Evolution* 3, no. 1: 188–194.
- Berlanga, H., J. A. Kennedy, T. D. Rich, M. C. Arizmendi, C. J. Beardmore, P. J. Blancher, G. S. Butcher, A. R. Couturier, A. A. Dayer, D. W. Demarest, W. E. Easton, M. Gustafson, E. Iñigo-Elias, E. A. Krebs, A. O. Panjabi, V. Rodriguez Contreras, K. V. Rosenberg, J. M. Ruth, E. Santana Castellón, R. Ma. Vidal, T. Will. 2010. Saving Our Shared Birds: Partners in Flight Tri-National Vision for Landbird Conservation. Cornell Laboratory of Ornithology: Ithaca, NY.
- Bled, F., Sauer, J., Pardieck K, Doherty, P., y Royle, J.A. (2013). Modeling Trends from North American Breeding Bird Survey Data: A Spatially Explicit Approach. *PLoS ONE* 8(12): e81867.
- Jones, J. P. G. (2011) Monitoring species abundance and distribution at the landscape scale. *Journal of Applied Ecology*, 48(1), 9–13.
- MacKenzie, D. I., y Royle, J.A. (2005). Designing occupancy studies: general advice and allocating survey effort. *Journal of Applied Ecology*, 42(6), 1105–1114.
- MacKenzie, D. I. (2006). *Occupancy estimation and modeling: inferring patterns and dynamics of species occurrence*. Academic Press.
- Newson, S.E., Johnston, A., Renwick, A.R., Baillie, S.R. y Fuller, R.J. (2012). Modeling large-scale relationships between changes in woodland deer and bird populations. *Journal of Applied Ecology*, 49(1): 278–286.

- Ortega-Alvarez, R., L.A. Sánchez-González, H. Berlanga, V. Rodríguez-Contreras y V. Vargas. (2012). Manual para monitores comunitarios de aves. Comisión Nacional para el Conocimiento y Uso de la Biodiversidad, Comisión Nacional de Áreas Naturales Protegidas, Corredor Biológico Mesoamericano-México. México.
- Ralph, C.J.; G.R. Geupel, P. Pyle, T.E. Martin, D.F. DeSante, y B. Milá. (1996). Manual de métodos de campo para el monitoreo de aves terrestres. Gen. Tech. Rep. PSW-GTR-159. Albany, CA: Pacific Southwest Research Station, Forest Service, U.S. Department of Agriculture, 46 p.
- Tulloch, A. I., Possingham, H. P., Joseph, L. N., Szabo, J., y Martin, T. G. (2013). Realizing the full potential of citizen science monitoring programs. *Biological Conservation*, 165, 128–138.

Glossary

This section defines some terms and concepts used in the manual.

Abundance: The number of individuals of the same species present in a given place and time.

Biodiversity: Or biological diversity, is the variety of life and encompasses several levels: genes, species, ecosystems, and the ecological and evolutionary processes that generate and maintain them.

Bird community: A group of populations of different bird species. All individuals of different bird species inhabiting a space at a given time.

Bird population: The set of all organisms of a species living in a given area.

Citizen science: The voluntary participation of the general public in the generation of data and information for projects to answer scientific research questions.

eBird: An international platform developed by the Cornell Laboratory of Ornithology for the entry, storage, and management of bird observation data collected by the public. It provides access to a real-time database on the distribution and abundance of all the world's birds to scientists, researchers, and amateur birders. It is the world's most important database and information base for developing citizen science projects.

Ecosystem: The set of organisms, populations, communities, and their environment, and the relationship between them.

Endemic species: Those whose distribution is restricted to a particular area or region, such as an island, a state, a country, or a continent.

Habitat: The place where an organism, population, or species community lives.

Mesoamerican Biological Corridor (cbm): Initiative for the conservation of biodiversity in priority areas of Mesoamerica that promotes knowledge and sustainable use of natural resources.

Migratory: Species that move from one region to another at different times of the year in response to environmental changes. Generally, these movements are cyclical and annual.

Playback: The use of song recordings and calls to attract birds.

Replicate: Each visit to a given point count during a sampling season.

Resident: A species that completes its life cycle in the same place throughout the year.

Sampling: The process by which specific field data are taken from a population, usually following a method or protocol, to infer knowledge that describes the entire population.

Scientific name: The unique and unrepeatable name given to each biological species based on a formal classification system. The scientific name is formed by two words, generally in Latin or Greek; the first corresponds to the genus (including several species) and the second to the species. For example, the scientific name for the Cinnamon Turtle is *Columbina talpacoti*.

Season: Period during which all the replicates of a sampling round are carried out.

Species: A group of organisms similar to each other in appearance, behavior, and evolutionary history, that can reproduce and leave fertile offspring.

Standardized protocol: Previously defined, mandatory and fixed procedure for completing a task (for example, bird monitoring).

APPENDIX 1



Datasheet and how to use it

If you are unable to use the mobile app for entering data and you need to enter data manually in the field, we provide below instructions and a data sheet for collecting information in the field. First, on the Field Data Sheet, note the name and number of monitors (group size) and the date and time of the start of the field trip. The **general location** refers to the name of the region or area being monitored, containing several point counts, for example, Los Tuxtlas Biosphere Reserve, Ejido San Miguel, or Cerro de las Cruces. **Land use** refers to the type of vegetation corresponding to the classification table found in a previous section of this manual, for example, pasture, forest, or oak forest. In the columns, note the observations made at each point count.

PROALAS: Latin American Landbird Program					
Name:					
Group Size:		Date (dd/mm/year):		Playback (Y/N):	
Start Time:		General Location:		Playback type(1/2):	
End Time:					
Species	Within 30m	Outside 30m	Species	Within 30m	Outside 30m
Start/end time and point/transect			8:15am, PROALAS-CBM-125-MX,8:25am		
<i>Species name</i>	#Individuals	# individuals	<i>Myarchus tuberculifer</i>	II	III

Field Data Sheet with an example of recording the species name and records inside and outside the sampling area border.

When you arrive at an established point count, note the start time of the count and record all individuals of each species observed within a minimum of 10 minutes or longer when bird activity is high. In the end, note the end time of the count for each point. Count the number of individuals of each species within each band, using the band where the individual was first detected. Some individual birds will move around within the count area during the 10-minute count. It is very important to include that individual in the tally for the band in which the observer first detected it.

To improve the accuracy of the observation distance, you can use marks or references in the field to estimate the distance inside and outside the point count

circle. It is important to note all individuals of each species that are seen or heard inside and outside the sampling area.

If necessary, you can move around inside the circle to identify species. Still, you should always return to the circle's center to differentiate between birds inside and outside the circle (Figure 5). At each point, start a new list and repeat the procedure. Again, all individuals of each species should be noted, regardless of whether they were seen at the previous point or on the way from one point to another. For example, if two individuals are observed outside the sampling area during the count but then move to the location of the next point, they should be noted as within the new one.

Flyovers: Some individuals fly over the sampling area without stopping. Record these individuals specifying that it is a 'flyover' not to be included in the analysis.

Species	Within 30m	Outside 30m
6:13, Start ZOHLG-001		
<i>Amazona albifrons</i>	1	1
<i>Colaptes rubiginosus</i>		1
<i>Ramphastus sulfuratus</i>	1	1
<i>Phaethornis longirostris</i>	1	
<i>Henichorina leucosticta</i>	1	
<i>Campylopterus hemileucurus</i>	1	
<i>Basileuterus culicivorus</i>	3	
<i>Setophaga pensylvanica</i>	1	2
<i>Myarchis tuberculifer</i>	2	
<i>Hylodichla mustelina</i>	1	
<i>Euphonia gouldi</i>		2
7:23, End ZOHLG-001		
7:30, Start ZOHLG-002		
<i>Aulacorhynchus prasinus</i>	1	1
<i>Cardellina pusilla</i>	1	
<i>Chlorospingus flavopectus</i>	2	
<i>Pheugopedius maculipectus</i>	1	1
<i>Ramphastus sulfuratus</i>		1
<i>Psarocolius montezuma</i>	1, F	
7:45, End ZOHLG-002		

In this example, in both points 1 (ZOHLG-001) and 2 (ZOHLG-002), *Ramphastos sulfuratus* was recorded; in point 1, a total of 2 individuals were detected (1 inside and 1 outside the sampling area), while in point 2, only 1 individual was seen outside the sampling area.

PROALAS: Latin American Landbird Program

Name:		Date (dd/mm/year):		Playback (Y/N):	
Group Size:		General Location:		Playback type(1/2):	
Start Time:		End Time:			

Species	Within 30m	Outside 30m	Species	Within 30m	Outside 30m
Start/end time and point/transect	# individuals	# individuals	8:15am, PROALAS-CBM-125-MX, 8:25am	II	III
<i>Species name</i>			<i>Myarchus tuberculifer</i>		

APPENDIX 2



Step-by-step instructions for PROALAS

- 1) Before starting your counting birds, write in the field notebook: date, site name, sampling start time, and the number of people who will do the count.
- 2) Note the point number and the time the count begins.
- 3) Record the number of individuals of each species observed during 10 or 15 minutes, within each distance band.
- 4) Record the time when you stop counting at that point and move to the next one.
- 5) If, during the walk from one point to another, one or more rare species or species of interest are observed, record it, noting that it was not part of a count. These records will be entered as separate observations in eBird using the 'Incidental' protocol.
- 6) For each point, repeat steps 2 to 5.

At the end of each set of counts, record when the day's sampling work is concluded.

APPENDIX 3



How to enter PROALAS data into eBird on the computer?

Once all the points or transects are registered in proalas@cornell.edu with the Excel format or directly in the eBird platform, you can start your monitoring. There are several protocols available in eBird; however, this manual only explains how to enter data using the PROALAS protocol for either point counts or transects. Each list must be entered individually; i.e., a list will be generated for each monitor for each point count/transect for each replicate.

Example:

If a monitor performs ten-point counts back and forth (i.e., two replicates per point), it will generate 20 lists. If another monitor performs the same points 20 min later, it will generate another 20 lists. This way, together they will have developed 40 lists total (four replicates of 10 points).

- To start uploading the information to the platform, log in to eBird using the username and password; click on the **Submit** tab (Figure 27).

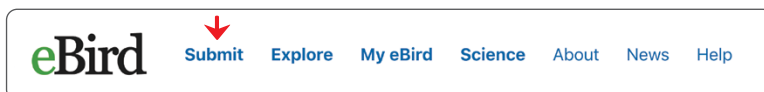

Figure 27. Location of the Submit tab that allows us to generate a new list and upload it to the platform.

The platform allows you to generate a new list by guiding you through 3 steps:

Step 1: Where did you observe birds?

- The first time you enter a point count location, select the option **Use latitude/longitude** (Figure 28).

1 2 3 Where did you bird?

Identify the location where you made your observations.

Choose from Your Locations

(19.49, -96.332) Continue

[Manage "My Locations"](#)

Find it on a Map

🔍 Enter a region

Use Latitude/Longitude 

Create a new location using latitude and longitude.

Figure 28. Using coordinates to enter a new point.

- Enter the coordinates in DECIMAL DEGREES or DEGREES MINUTES SECONDS (Figure 29) and click **Continue**.

1 2 3 Where did you bird?

Enter Latitude and Longitude in Decimal Degrees * = Required

Use Degrees Minutes Seconds

* **Latitude:** 18.579516
e.g., 42.8638 – Latitude should be negative in the Southern Hemisphere.

* **Longitude:** -89.4249.17
e.g., -94.58703 – Longitude should be negative in the Western Hemisphere.

◀ Continue ▶

Figure 29. Enter the coordinates of a new location (point count/start of transect).

- The platform will locate the point you entered on a map. In the **Enter location name** section, type the name of the point (Figure 30). Remember that this is only necessary when the PROALAS point count or transect is registered for the first time.

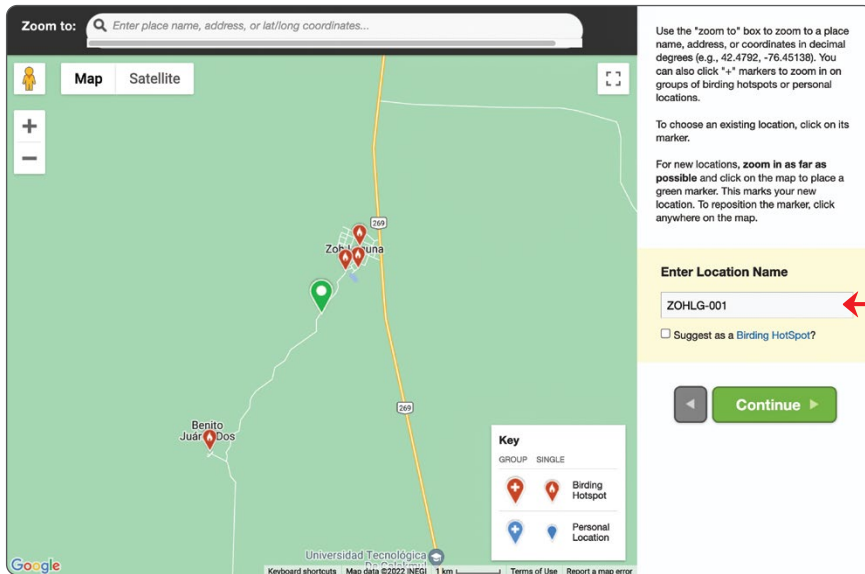

Figure 30. Window for naming and registering a new location (point count). Note how the point has been named in the example following the same code described above.

- Once the location has been created, it will be saved in the system, and the next time you make checklists at that point, you only have to look for its name in the list in the option **Choose from your locations** (Figure 31).

The screenshot shows a form titled "Where did you bird?" with three numbered steps. Step 1 is active. The main instruction is "Identify the location where you made your observations." Under the heading "Choose from Your Locations", there is a dropdown menu with "ZOHLG-001" selected and a "Continue" button. Below the dropdown is a link "Manage 'My Locations'". Under the heading "Find it on a Map", there is a search input field with a magnifying glass icon and the placeholder text "Enter a region". Under the heading "Use Latitude/Longitude", there is a sub-instruction "Create a new location using latitude and longitude." At the bottom, there is a link "Select an entire county, state, or country".

Figure 31. In the “Choose from your locations” option, you will be able to select your already registered point counts.

Step 2: Date and effort

Observation date: When the list was made.

Observation Type: In the drop-down list of **Other**, select PROALAS-Point Count (2 bands), PROALAS Point Count (3 bands) or PROALAS Mini-transect as appropriate (Figure 32).

Start time: When the count started (am/pm or 24 h).

Duration: Time spent counting at the point/transect (between 10 – 15 minutes).

Figure 32. The information required in the Date and effort section is displayed.

Step 3: What did you see or hear?

To set how you prefer to view the names of the birds, click on **Preferences** (Figure 33) and select the desired option. We recommend using English common names and scientific names as they are the most standardized globally. To continue, click on **Save Preferences**.

Figure 33. Preferences menu of how you want to view the data entry list.

- You can start entering the bird data by entering the total number of individuals seen or heard during the count (Figure 34 a).
- To record the number of individuals in each distance band, click on **Add Details** next to the species name. In the **Distance Bands** section, indicate the number of individuals detected within each distance band (Figure 34 a).
- To facilitate the recording process, you can activate the **Group by Most Likely function** (Figure 34 b) to display only the most common species; using the search bar; you can type the name of a particular species and quickly locate it.

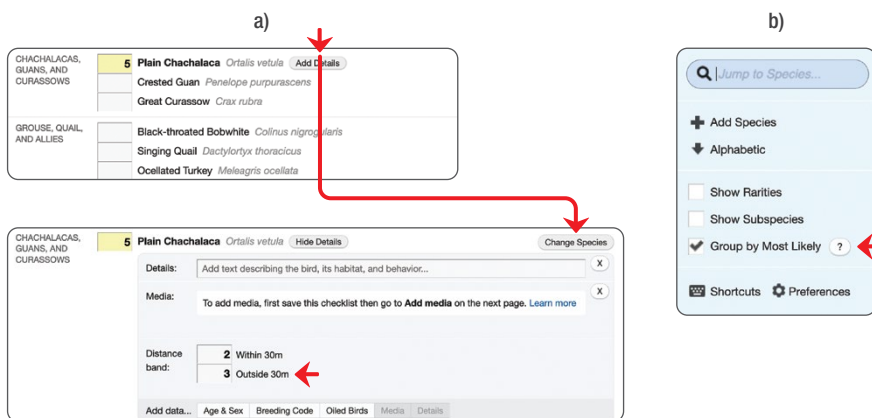

Figure 34. a) Example of how to display the list of landbirds with common names in Spanish and scientific names, add records inside and outside the 30 m for 2 band point count, and b) filter the list to only the most probable ones in the area.

NOTE

Optional: In the “Add Details” section, we can describe some critical aspects of the record (description of the bird, the behavior we observed, its habitat, etc.); in the “Media” section, you can add photographs, audios, or videos; specify the age and sex (if it was possible to determine it) and select one of the “Breeding codes” if appropriate.

- If a species is not found in the list, you should select the **Show Rarities** function and search again (Figure 35 a). For species marked with the **Rare** label, the platform will ask you to describe the details of the record: under what conditions it was seen (whether we heard or saw it, at what distance, for how long, and in what visibility conditions), and how it was identified and differentiated from other similar species. If a photograph or recording is available, you can include it in the **Media** section (Figure 35 b).

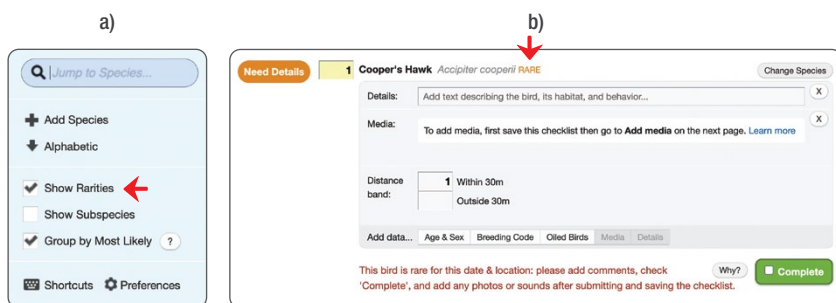

Figure 35. a) Box to show rare species in the list and
b) menu of details to provide for a species marked as rare.

- Once all the records have been entered, answer the question, “Are you submitting a **complete list** of the birds you were able to identify?” (Figure 36 a).
- It is important to answer this box honestly as it represents a critical piece of information and will have significant consequences on how these counts are analyzed. Answer **yes** when reporting all the birds you could identify, not just the highlights. Always answer yes unless you expressly exclude some species from your list (for example, exotic birds).
- Finally, click on **Submit**. After doing this, you can still check for errors and make necessary changes (Figure 36 b).
- Checklists can be shared with other eBirders by clicking on the **Share** button and writing down the usernames or emails associated with their eBird account (Figure 36 b).

- To edit any information of the list, click on the **Checklist tools** button and select from the menu the aspect you wish to edit. This menu also allows you to download the list, share it or send it to your email (Figure 36 c).

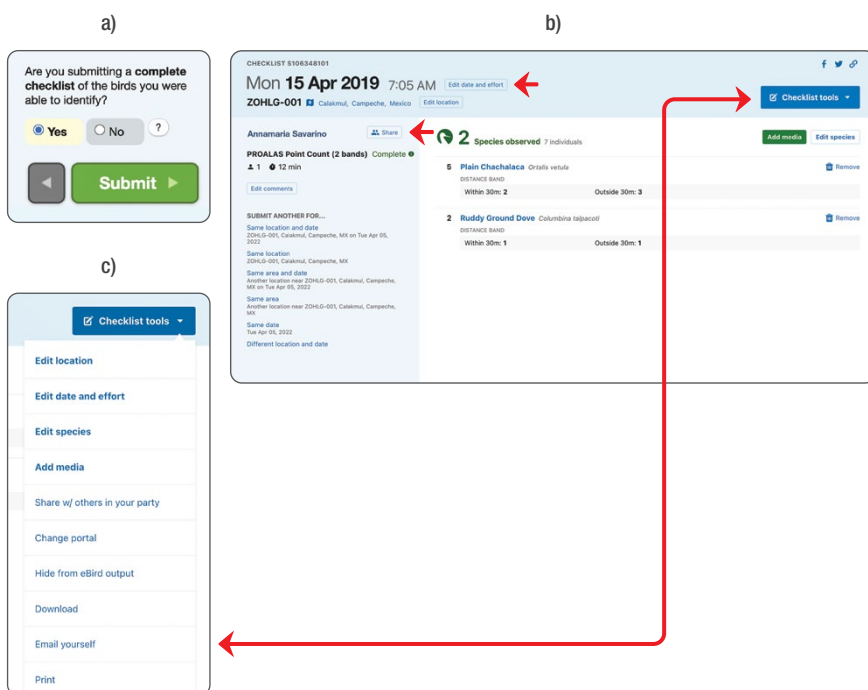

Figure 36. a) Window to select if the checklist is complete. b) Example of a complete PROALAS checklist. Note how there is a checkbox for the band within 30 m and outside 30 m. Modifications to Location, Date and Effort, Species list can be made by clicking on Checklist tools menu. Share button to add other observers to the list.

APPENDIX 4



Individual and group accounts for PROALAS monitoring in eBird

Group accounts in eBird can be valuable tools for associating and sharing data among observers for monitoring purposes. **Each person contributing to the group account should have their eBird account.** This way, everyone can keep track of how their contributions add to the PROALAS monitoring project while keeping track of personal sightings when monitoring as a group. You can also go birding for fun during your free time!

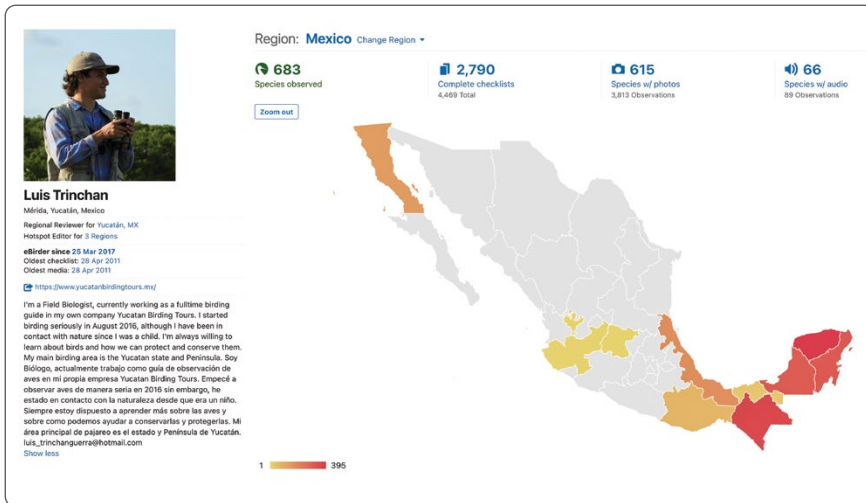

Figure 37. An example of an individual eBird account for tracking sightings and personal records

After a list is submitted into the account, it should be shared with the group account. This will consolidate the lists from the monitoring project into a single account for easy management and analysis.



Figure 38. Example of a group account for community monitoring through eBird.

When a list of birds is shared, a link is created between the original and shared list in the eBird system. Each list can be edited independently without affecting the other, except uploaded photos and recordings; these will appear in both. This means that if you are on a group birding trip, you can make a record of the landbirds that everyone has seen (even if you have not seen some), enter the list, and share it with the group account. After the group account administrator has accepted the list, you can delete the species you did not see, which will keep your records accurate. Noting species not seen by everyone makes the process of reconciling the lists easy (for example, “seen only by Anna” or “not seen by Joseph”).

You can share lists from the web portal and the eBird mobile app. For more information on how to share and accept eBird lists, we suggest you read the instructions here: <https://support.ebird.org/en/support/solutions/articles/48000625567-checklist-sharing-and-group-account>

VerAves Submit Explore My eBird Science About News Help

CHECKLIST 555892832

Sat 4 May 2019 5:20 PM

Poligono/1/APFFMN/Parque Cancún Benito Juárez, Quintana Roo, Mexico

Red de Monitoreo Comunitario Mayan Jays

Cecilia Alvarez (PAU CANCUN) Green Jay Bird Conservancy

Traveling Complete 12 2 hr, 30 min 0.5 km

MEDIA POWERED BY MACAULAY LIBRARY

45 Species observed 124 Individuals 1 Species with photos

- 5 Plain Chachalaca *Ortalis vetula*
- 6 Red-billed Pigeon *Patagioenas flavirostris*
- 2 Eurasian Collared-Dove *Streptopelia decaocto*
- 1 Ruddy Ground Dove *Columbina talpacoti*
- 1 White-tipped Dove *Leptotila verreauxi*
- 12 White-winged Dove *Zenaidura macroura*
- 1 Smooth-billed Ani *Crotophaga ani*
- 6 Groove-billed Ani *Crotophaga sulcirostris*
- 1 Lesser Nighthawk *Chordeiles aculipennis*
- 1 Ruby-throated Hummingbird *Archilochus colubris*
- 1 Canivet's Emerald *Cyananthus canivetti*
- 1 Cinnamon Hummingbird *Amazilia rutila*
- 1 White Ibis *Eudocimus albus*

Figure 39. Example of a checklist with multiple observers shared with the community monitoring group account.

The group account administrator should click on **Contacts** under the **My eBird** tab to set up each monitoring participant as a friend for the account. This way, the shared lists will be automatically copied to the account without the administrator accepting each one manually. To download observation data, you can go to **My eBird** and click **Download My Data** to obtain a spreadsheet of all the account data. This spreadsheet can be used for data manipulation and analysis.

Group accounts should be removed from the Top 100 lists by going to **My eBird**. Click on by **Preferences** in your eBird profile, and under **Data Privacy**, check the **Hide my data from Top 100**. This ranking is designed to track the achievements of individual observers, so it would be unfair to have group accounts in the Top 100.

APPENDIX 5



Occupancy models

Biodiversity studies commonly seek to understand patterns of animal distribution and abundance. However, the effort, time, and cost required to estimate this can be very high, and institutions or working groups may not have the tools and resources to carry them out. Other alternatives allow the identification of the status of populations or communities, which may be more appropriate and less expensive in terms of data collection. The study of occupancy is a valuable alternative to study the distribution of species and the factors that determine whether or not a species is present at a site.

These studies require data on the presence and absence of the species of interest. Rarely will a species be 100% detectable, so keep in mind that if an animal is not detected during the study, this does not imply that it is absent from the site. Since detectability can vary between sites and may be related to characteristics of the sampling day, such as weather conditions, it is important **not to assume** that the detection/non-detection data are actual presence/absence. The proportion of sites where a species is frequently detected will underestimate actual occupancy in an area of interest.

What are occupancy models?

Occupancy is the proportion of area, patches, or sampling units where a species is present. Estimating abundance is very difficult for rare and inconspicuous species, whose probability of being detected is low ($p < 1$), but studying their occupancy is possible. Occupancy models were created to consider the imperfect detection of species and are based on making repeated observations at a site to generate a detection/non-detection history and thereby estimate the probability of detection. As mentioned, the detectability may vary according to the site's characteristics or the sampling day conditions. At the same time, occupancy probability will only be related to the environmental factors at a given time.

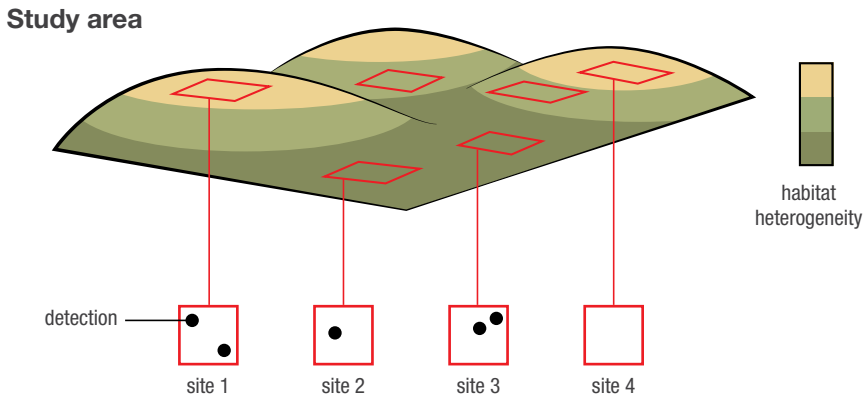

Figure 40. Definition of the study area with different habitat characteristics represented in different colors (source of variability). Example of location of sites (sampling units) and detections of the species of interest.

Parameters:

Occupancy probability (Ψ): The probability that a species occupies a site or a random sampling unit.

Probability of detection (p_j): The probability of detecting the species at a site during a specific sampling given its presence at the site.

Necessary information/Definition of the study site: This can be a natural site such as a pool of water or delimited by us, such as a point count or a transect.

Detection history: A record of whether a species was detected or not during each visit at each sampling site.

The site's characteristics (covariates) include vegetation cover, trunk diameter, or contaminant concentration. Likewise, Information on the sampling event should also be collected, that is, the conditions in which the visit was made, such as the time, how long the sampling lasted, the number of people observing at the same time, and sometimes precipitation or temperature.

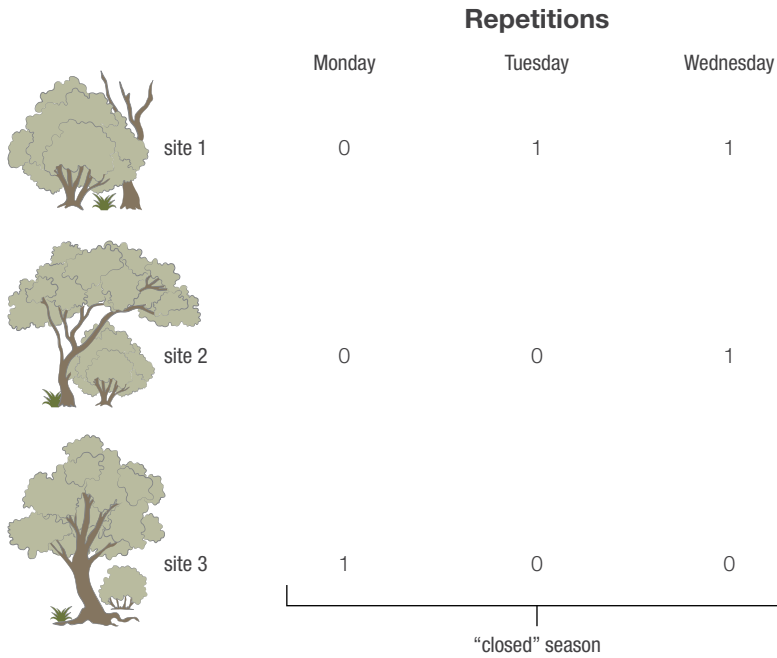

Figure 41. Example of a history of detections of a species per site (1,2,3) in each visit (Monday, Tuesday, and Wednesday), where 1 represents that we could detect a species, while 0 means no detection. Such visits or repetitions must be made during a period that can ensure a season closed to changes.

Assumptions

For the interpretation of occupancy models to work and be robust, several assumptions need to be met:

1. **Occupancy status is closed to changes:** When estimating occupancy, it is necessary to define a season where habitat and occupancy variables are constant and do not change, as if looking at a photograph. These changes could include migrations, significant egg hatching events, or exceptionally high mortality of individuals in a short period. The definition of this season will depend on the species' natural history and habitat. For example, making three visits in a week to a site might ensure a closed

season, while three visits in two months might instead violate the assumption, as both site and population conditions are likely to change within two months.

2. **Site independence:** The probability of detecting a species at one site is independent of the possibility of detecting it at another location. It is essential to properly design how the area is to be sampled so that sites are of sufficient size and spacing to ensure such independence.
3. **No unexplained heterogeneity in occupancy:** The probability of occupancy is the same in all sites, or these differences can be explained by the site characteristics (covariates) that can be included in the model.
4. **No unexplained heterogeneity in detectability:** The probability of detection is the same at all sites. Site characteristics or sampling conditions can explain these differences, which can be included in the model.
5. **Species are not misidentified:** It is imperative to identify species correctly and not falsely detect them when absent from the site.

What are occupancy models for?

In recent years there has been a significant diversification in the applications of occupancy models. Among the most prominent is estimating the geographic distribution of species, going hand in hand with identifying associated habitat variables (habitat use) and resource selection. Occupancy models can estimate the dynamic rates that generate the observed occupancy patterns, such as colonization and extinction rates. These rates are calculated over time (for example, over more than one season), either from month to month or year to year. It is also a valuable tool for estimating species richness in a community and studying the dynamics of invasive species and the dynamics of animal communities according to the relationships between different species. Changes in occupancy patterns can indicate the impact of climate change on species' niches, or they can tell how they respond to the presence of pressures such as pollutants, invasive species, or habitat fragmentation. Applications have been extended to the field of paleontology, estimating distributions based on fossil data or in medicine with the study of the distribution and dynamics of infectious diseases (MacKenzie et al., 2017).

Examples and use cases of occupancy models

The occupancy models have analyzed various taxonomic groups and data collection methods. For example, acoustic recordings of bats have been used to estimate tropical diversity (Meyer et al., 2011) or to assess the impact of roads on community composition and activity (Berthinussen and Altringham, 2012). In amphibians, the essential variables to be taken into account have been identified to design population monitoring programs (Weir et al., 2009) and evaluate the effect of habitat fragmentation on species distribution patterns (Vos and Chardon, 1998). In the field of epidemiology, it has been used to understand the dynamics of vectors and hosts of amphibians (Adams et al., 2010) and fish pathogens (Thompson, 2007) or even to study palm infestations by insects (Abad-Franch et al., 2010). From traces and camera trap photos, it has been possible to estimate the distribution of terrestrial carnivore populations (Karanth et al., 2011; Long et al., 2011). Taking as an example a study with dragonflies (Kéry et al., 2010), lists from flora and fauna databases also provide the necessary information to estimate distributions robustly.

Regarding birds, models have been used to study the richness and structure of the community (Kéry and Royle, 2009), analyze changes in occupancy over time in fragmented habitats and landscape variables that determine the use of resources (Frey et al., 2012; Mackenzie, 2006), the interaction between species and how the occupancy of one bird is affected by that of another (Olson et al., 2005) and have proven to be more robust in predicting geographic distribution than other models when using presence-only data (Royle et al., 2012). In addition to being fragmented, habitats suffer constant changes in management such as controlled burning, logging, reforestation, cultivation, or clearing of vegetation to create pastures. There are many examples where occupancy models have helped us to understand the effects of management on bird community structure and its population dynamics in grasslands (Pons et al., 2003), jungles, forests (Nappi et al., 2010; Saracco et al., 2011) and mosaics of agricultural land with native vegetation and reforestation (Cunningham et al., 2008).

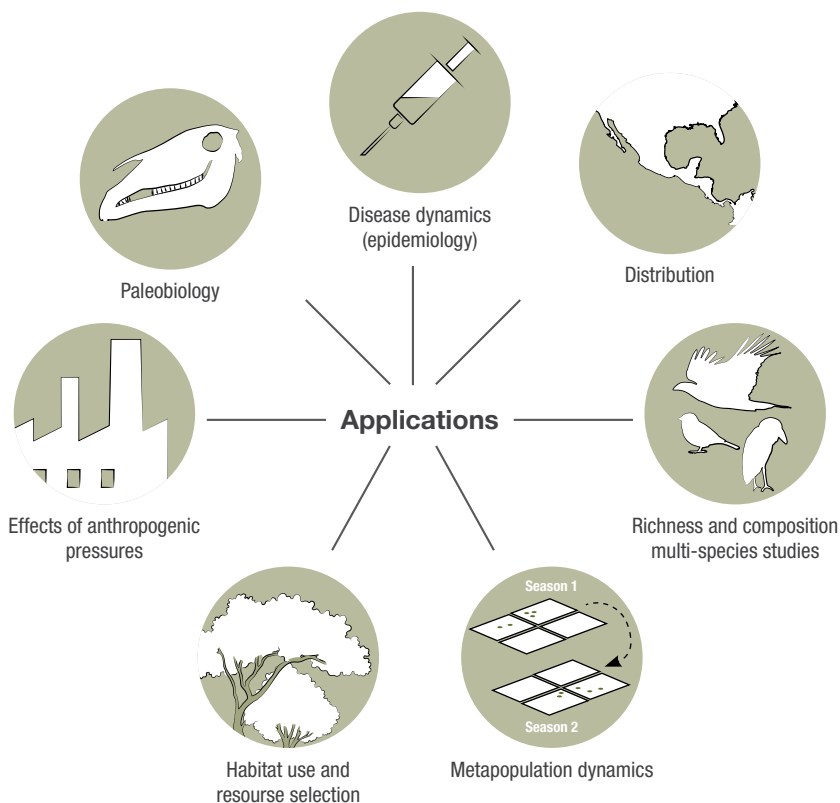

Figure 42. Applications of occupancy models to different fields of science (MacKenzie et al., 2017).

Citizen science and bird monitoring

International fauna databases such as eBird allow the collection and storage of information on which species occur and which do not occur worldwide. However, to know the impact on populations, it is necessary to go beyond the creation and accumulation of lists, in this case of landbirds. Using tools such as occupancy models does not require significant changes in the data collection effort, only subtle adjustments to ensure the models' assumptions. We can say much more about citizen science data by using appropriate analytical tools and thus obtaining timely information to exercise an informed action plan.

The inclusion of local communities is crucial in creating environmental management plans that are both productive and sustainable. The guidelines and practices should be based on the productive needs of the community and critical ecological characteristics that allow for the subsistence of flora and fauna. Including community monitors in data collection to model the response of biodiversity to different management scenarios is of utmost importance in developing effective forestry practices.

Example with forest management

In a study in the Sierra Juárez of Oaxaca, Mexico, data collected by community monitors were used, taking into account the needs and forestry practices of the Union of Zapotec-Chinanteco Forest Producing Communities of the Sierra Juárez (UZACHII). The response of the landbird community to different forest management scenarios that formed a mosaic of habitats with several vegetation characteristics was modeled. It was concluded that selective forest management is not entirely negative for landbirds since it maintains a heterogeneous habitat and vegetation structure; however, intensive practices were not favorable for most landbirds due to the removal of key vegetation. This study represents an example of the active inclusion of the community to understand the effects that forest management has on birds and thus propose sustainable practices aligned with regional productive needs (Ortega-Álvarez et al., 2018).

References

- Abad-Franch, F., Ferraz, G., Campos, C., Palomeque, F. S., Grijalva, M. J., Aguilar, H. M., y Miles, M. A. 2010. Modeling Disease Vector Occurrence when Detection Is Imperfect: Infestation of Amazonian Palm Trees by Triatomine Bugs at Three Spatial Scales. *PLoS Neglected Tropical Diseases*, 4(3), e620.
- Adams, M. J., Chelgren, N. D., Reinitz, D., Cole, R. A., Rachowicz, L. J., Galvan, S., Leu, M. 2010. Using occupancy models to understand the distribution of an amphibian pathogen, *Batrachochytrium dendrobatidis*. *Ecological Applications*, 20(1), 289–302.
- Berthinussen, A., y Altringham, J. 2012. The effect of a major road on bat activity and diversity. *Journal of Applied Ecology*, 49(1), 82–89.

- Cunningham, R. B., Lindemayer, D. B., Crane, M., Michael, D., Christopher, M., Montague-Drake, R., y Fischer, J. 2008. The Combined Effects of Remnant Vegetation and Tree Planting on Farmland Birds. *Conservation Biology*, 22(3), 742–752.
- Frey, S. J. K., Strong, A. M., y McFarland, K. P. 2012. The relative contribution of local habitat and landscape context to metapopulation processes: a dynamic occupancy modeling approach. *Ecography*, 35(7), 581–589.
- Karanth, K. U., Gopalaswamy, A. M., Kumar, N. S., Vaidyanathan, S., Nichols, J. D., y MacKenzie, D. I. 2011. Monitoring carnivore populations at the landscape scale: occupancy modeling of tigers from sign surveys. *Journal of Applied Ecology*, 48(4), 1048–1056.
- Kéry, M., Gardner, B., y Monnerat, C. 2010. Predicting species distributions from checklist data using site-occupancy models. *Journal of Biogeography*, 37(10), no-no.
- Kéry, M., y Royle, J. A. 2009. Inference About Species Richness and Community Structure Using Species-Specific Occupancy Models in the National Swiss Breeding Bird Survey MHB. En *Modeling Demographic Processes in Marked Populations* (pp. 639–656). Boston, MA: Springer us.
- Long, R. A., Donovan, T. M., MacKay, P., Zielinski, W. J., y Buzas, J. S. 2011. Predicting carnivore occurrence with noninvasive surveys and occupancy modeling. *Landscape Ecology*, 26(3), 327–340.
- Mackenzie, D. I. 2006. Modeling the Probability of Resource Use: The Effect of, and Dealing with, Detecting a Species Imperfectly. *The Journal of Wildlife Management*, 70(2), 367–374.
- MacKenzie, D. I., Nichols, J. D., Royle, J. A., Pollock, K. H., Bailey, L. L., y Hines, J. E. 2017. *Occupancy estimation and modeling: inferring patterns and dynamics of species occurrence* (2a ed.).

- Meyer, C. F. J., Aguiar, L. M. S., Aguirre, L. F., Baumgarten, J., Clarke, F. M., Cosson, J.-F., ... Kalko, E. K. V. 2011. Accounting for detectability improves estimates of species richness in tropical bat surveys. *Journal of Applied Ecology*, 48(3), 777–787.
- Nappi, A., Drapeau, P., Saint-Germain, M., y Angers, V. A. 2010. Effect of fire severity on long-term occupancy of burned boreal conifer forests by saproxylic insects and wood-foraging birds. *International Journal of Wildland Fire*, 19(4), 500.
- Olson, G. S., Anthony, R. G., Forman, E. D., Ackers, S. H., Loschil, P., Reid, J. A., ... Ripple, W. J. 2005. Modeling Site Occupancy Dynamics for Northern Spotted Owls, with Emphasis on the Effects of Barred Owls. *The Journal of Wildlife Management*, 69(3), 918–932.
- Ortega-Álvarez, R., Zúñiga-Vega, J. J., Ruiz-Gutiérrez, V., Berrones Benítez, E., Medina Mena, I., y Ramírez Felipe, F. 2018. Improving the sustainability of working landscapes in Latin America: An application of community-based monitoring data on bird populations to inform management guidelines. *Forest Ecology and Management*, 409, 56–66.
- Pons, P., Lambert, B., Rigolot, E., y Prodon, R. 2003. The effects of grassland management using fire on habitat occupancy and conservation of birds in a mosaic landscape. *Biodiversity and Conservation*, 12(9), 1843–1860.
- Royle, J. A., Chandler, R. B., Yackulic, C., y Nichols, J. D. 2012. Likelihood analysis of species occurrence probability from presence-only data for modeling species distributions. *Methods in Ecology and Evolution*, 3(3), 545–554.
- Saracco, J. F., Siegel, R. B., y Wilkerson, R. L. 2011. Occupancy modeling of Black-backed Woodpeckers on burned Sierra Nevada forests. *Ecosphere*, 2(3), art31.
- Thompson, K. G. 2007. Use of Site Occupancy Models to Estimate Prevalence of *Myxobolus cerebralis* Infection in Trout. *Journal of Aquatic Animal Health*, 19(1), 8–13.

- Vos, C. C., y Chardon, J. P. 1998. Effects of habitat fragmentation and road density on the distribution pattern of the moor frog *Rana arvalis*. *Journal of Applied Ecology*, 35(1), 44–56.
- Weir, L. A., Royle, J. A., Nanjappa, P., y Jung, R. E. 2009. Modeling Anuran Detection and Site Occupancy on North American Amphibian Monitoring Program (NAAMP) Routes in Maryland. [http://dx.doi.org/10.1670/0022-1511\(2005\)039\[0627:MADASO\]2.0.CO;2](http://dx.doi.org/10.1670/0022-1511(2005)039[0627:MADASO]2.0.CO;2).

APPENDIX 6



Merlin: A Field Guide on Your Cell Phone

The Cornell Laboratory of Ornithology developed Merlin Bird ID, a cell phone application to help identify bird species in different locations worldwide. The app is free and available for iOS and Android phones in 15 languages, including Spanish, Portuguese, and French.

Merlin has four main ways to help us identify birds, 1) from photographs (Photo ID), 2) with the description of an observed species (Start Bird ID), 3) from Sound recordings (Sound ID) and 4) as a mobile identification guide (Explore Birds–Probable Birds).

The Cornell Lab 
Merlin[®]



Figure 43. Merlin Bird ID logo.

BEWARE! Before going to the field, research what functions you want to use; some require additional downloads, and therefore, without a signal, you will not be able to use that part of the application. We recommend doing these downloads over Wi-Fi, as the packs can be large and consume many data.

An essential thing to have the app working is the download of packages; these contain information about the birds by geographical regions. Although some packages do not yet include 100% of the species, these are becoming increasingly complete and continually updated. The following sections detail the download and use of the packages and other identification tools.

NOTE

Remember that you need to have an email associated with an eBird account to use Merlin.

1. Installation and registration

Search for “Merlin Bird ID” in the app store (Android or iOS), and install the app. When you open the app for the first time, enter your email address, preferably the one associated with your eBird account, if you already have one (Figure 44 a and b). Select “Allow” to allow the app to access the phone’s GPS services (Figure 44 c).

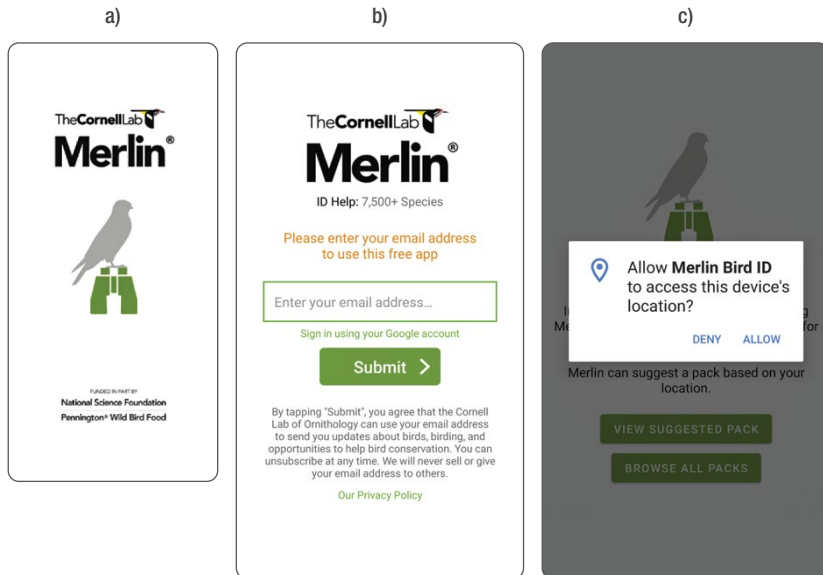

Figure 44. Screens for registration and access to GPS services.

2. Downloading and installing packs

In the next screen that will appear immediately, the app will suggest a bird package based on the coordinates that your phone registers. Click **Install** (Figure 45a) if you agree to install that pack. You can then browse and download other packages by going to the menu (three bars in the upper left corner), selecting the **packs** option, and choosing the one you want to download. We suggest having a Wi-Fi signal to download them, as many are over 500 MB in size. We also recommend ensuring you have enough space on your phone or get an external memory card and select the SD Card as the storage location for the material (Figure 45 c).

This last option is found by entering the menu and clicking **Preferences**. In this same window, you can specify the language of the common names and display scientific terms (Figure 45 c).

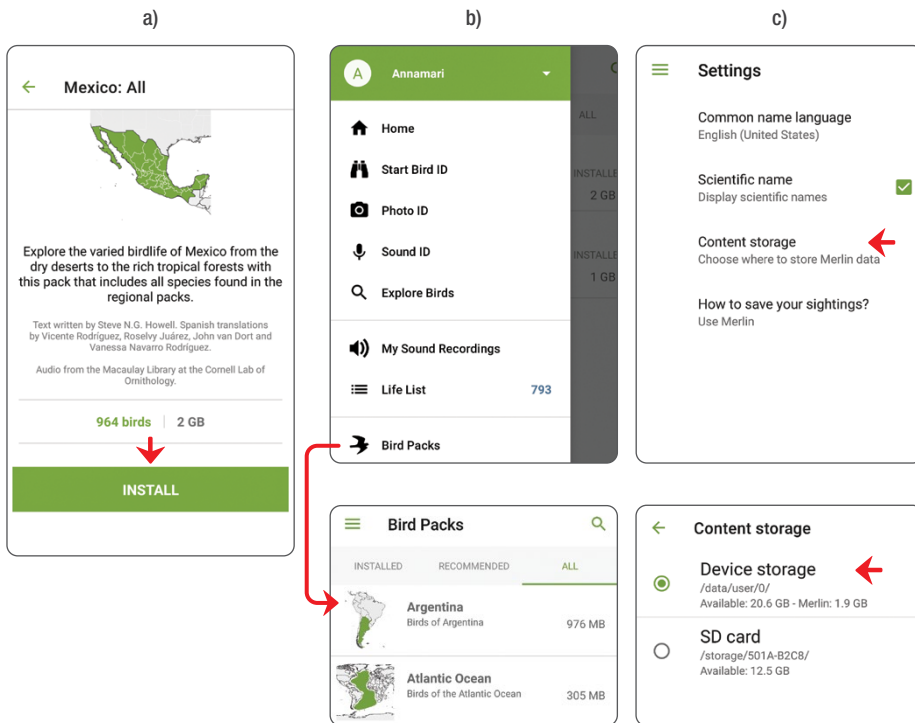

Figure 45. a) Suggested pack, b) search for packs to download, and c) Names and storage preferences menu.

3. Species identification

To start the species identification, click the **Start Bird ID** button (Figure 46 a). Merlin will guide you through five simple questions to approximate the species you wish to identify:

- i. **Where did you see the bird?** (Figure 46 b). Here you can use your **current location** if the bird you are trying to identify was seen near you. If it is a

bird from another area, use either the **Search** bar function or the **Select from map** function (Figure 46 b). For the latter, you will need to locate yourself in the region where you saw the bird and click **Use this location** (Figure 46 c).

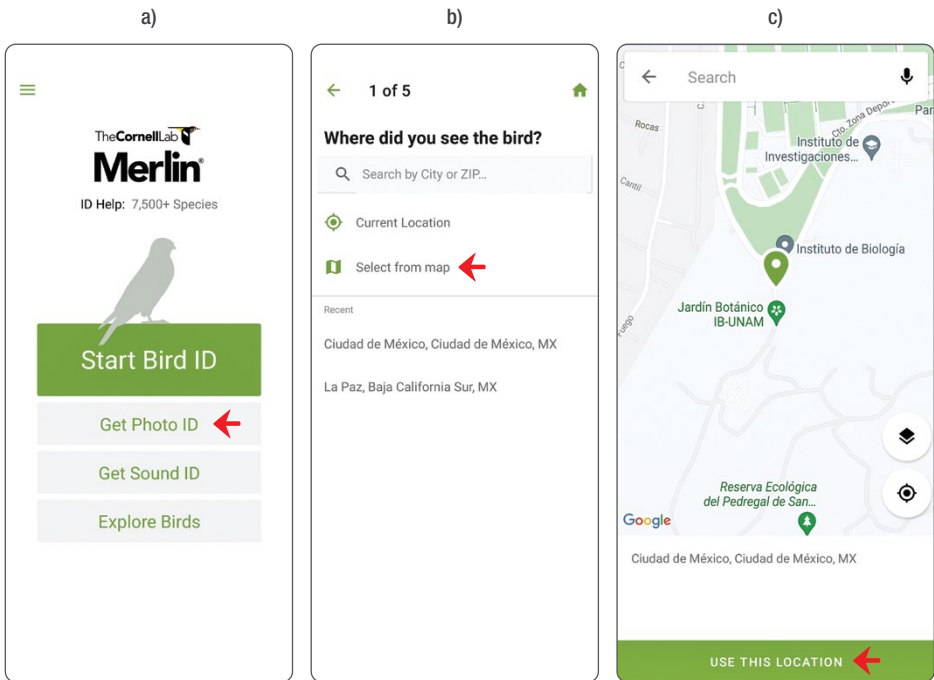

Figure 46. a) Button to start the identification menu, b) options to enter the location of the bird, and (c) screen to navigate the map to the location of the bird you wish to identify.

- II. **When did you see the bird?** (Figure 46 a) Indicating the date we saw the bird can help filter out migratory or transient species at that time of the year.
- III. **What size was the bird?** (Figure 46 b). You should choose one of the seven size options that you think most closely matches the bird you observed in this item. A sparrow, a thrush, a crow, and a goose serve as reference sizes.

- IV. **What were the main colors?** (Figure 46 c). In this window, you can choose up to three primary colors that you have perceived in the bird.

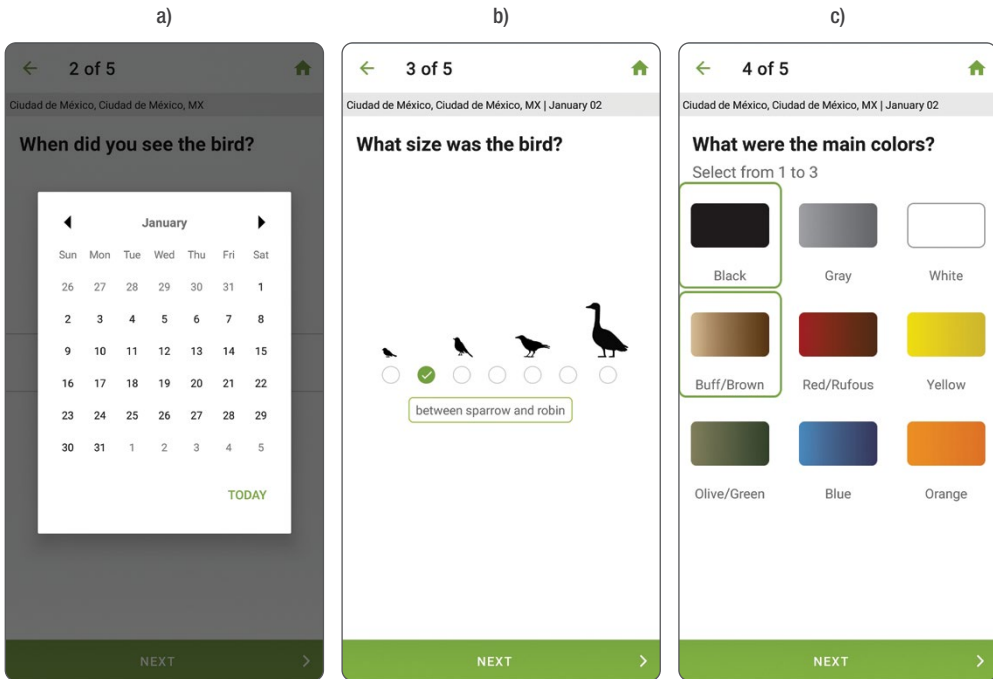

Figure 47. a) Specification of the date the bird was observed, b) approximate size, and c) the three primary colors of the bird to be identified.

- V. **Was the bird...?** (Figure 48 a) In this window, you must specify the activity and where you saw the bird; this helps filter birds depending on their behavior.
- VI. **Best Matches** (Figure 48 b). After the above questions, Merlin will display a list of probable birds corresponding to the criteria entered, which simplifies the search effort and maximizes the possibility of making a correct identification from photographs. You can explore each option, listen to their songs and calls, and view several photos by species. When you are

sure which bird you were looking for (Figure 48 b), click on it and then click on “This is my bird.” Remember that the first option is not necessarily the correct one.

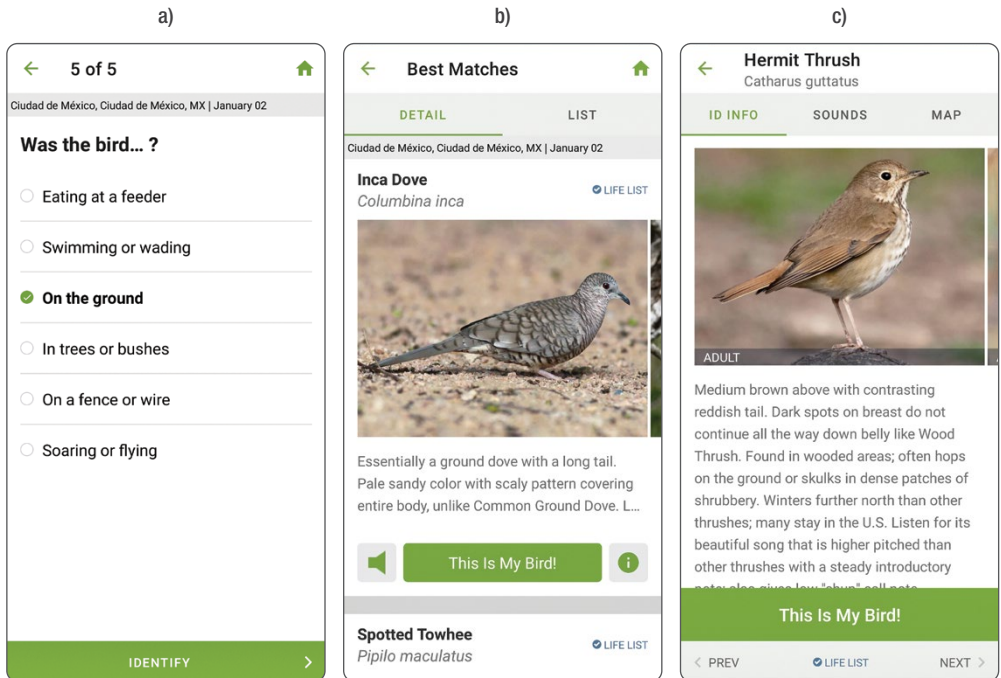

Figure 48. a) Specification of the behavior or place where the bird was, b) list of results and c) window of a species with the option to indicate if it was the bird identified.

NOTE

Remember that Merlin helps us narrow down a range of species options based on the information we provide, but the result is not necessarily definitive. Many bird species are unmistakable, but others are difficult to determine, either because there are one or more similar species, plumage variations, sexual dimorphism, or their field markings are not obvious. As you gain experience in observation and identification, the difficulty will gradually decrease.

4. Exploring Bird Packs and Using Filters

To see the birds you have installed on your phone, click **Explore birds** on the main Merlin screen.

- Filters. You can browse the species library by filtering them appropriately for the situation. Click the three triangle-shaped bars to enter the filter menu (Figure 49 a). Here you can either filter by the bird packs you have installed or by likely birds according to a location or season of your choice (Figure 49 b).
- Select a specific date and location to view the list of likely birds. You will notice a bar under the name of each species. This represents how likely it is to detect the bird according to the time of year you are at, with the start of the bar being January and the end, December. Note how for migratory species, the bar narrows until it disappears in a particular season. At the same time, for resident birds, it remains more or less constant in thickness throughout the year (Figure 49 c).

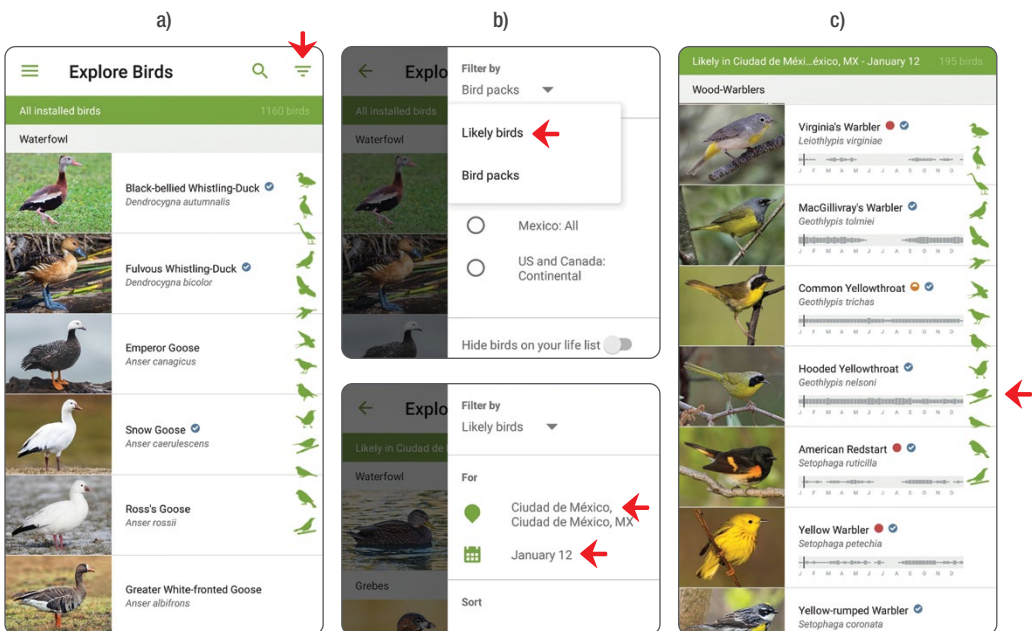

Figure 49. a) Location of the filter menu, b) by installed bird packs, or c) by locality and seasonality of the year.

- c) Species visualization. By clicking on each species, you can read a brief description and browse through several photographs by clicking on **ID Info** (Figure 50 a). If you click on **Sounds** (Figure 50 b), you can explore songs and calls; while clicking on **Map** (Figure 50 c), you can see the distribution map with a color code indicating the areas where the bird is a year-round resident, breeds, winters, or transits during its migration.

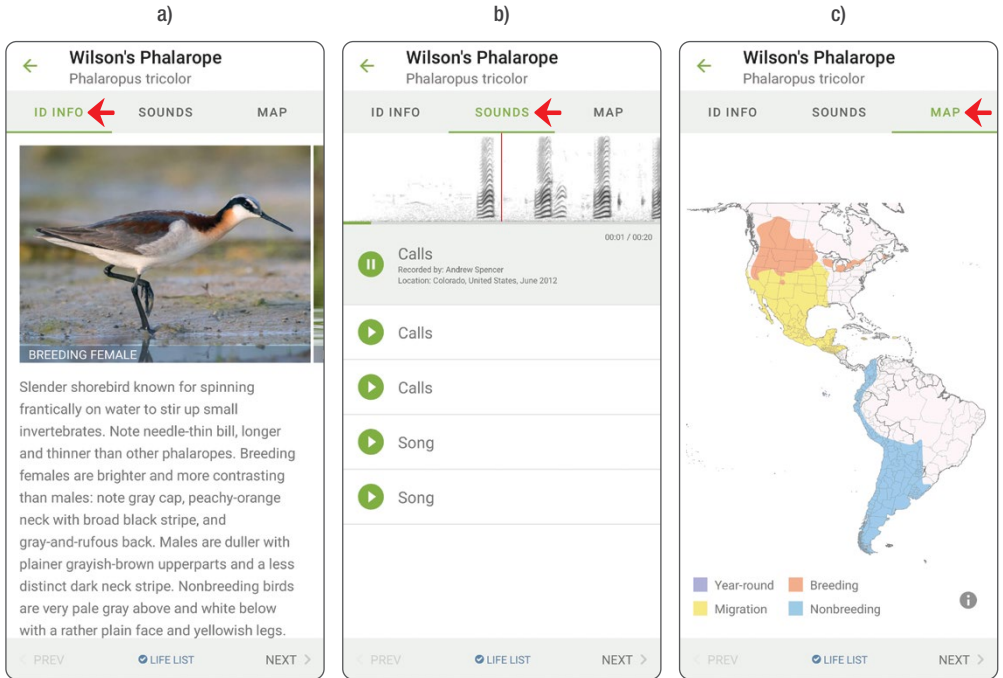

Figure 50. a) The “ID Info” tab displays a brief description of the species and several photographs, b) the “Sound” tab, various songs and calls, and c) the “Map” tab displays the distribution according to the bird’s migratory cycle.

Birds are an essential component of ecosystems because they perform vital functions for healthy ecosystems, such as seed dispersal and predation, pollination of many plant species (including species of economic importance), regulation of insect and rodent populations (some of which are potential pests) and also in the recycling of organic matter and carrion that help to prevent the spread of disease. They are a very sensitive group of animals that respond quickly to changes in the environment, which makes them excellent indicators of changes in the quality of the environment.

Monitoring and counting birds, using specialized techniques and methods, allows us to estimate the size of their populations, know their trends, and detect changes in their abundance and detectability in response to human activities, such as the application of management and restoration measures in a natural protected area, changes in land use, deforestation, agriculture, and also to natural phenomena such as hurricanes, fires or floods. The information derived from monitoring helps plan management actions and make informed decisions to conserve species and habitats.



The **Cornell** Lab
of Ornithology 

nabci
CONABIO
México 